

0:120221\22-0020 SAPELO ISLAND NATURE TRAIL SURVEY\DWG\22-0020\10.DWG 11/16/2022 12:21 PM

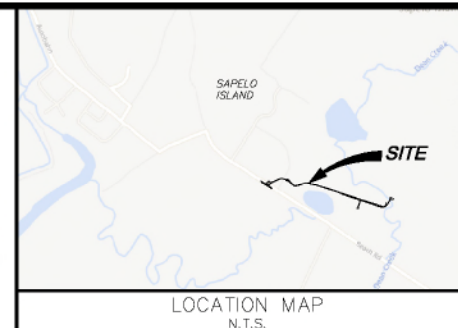

NO.	REVISION DESCRIPTION	DATE



EMC ENGINEERING SERVICES, INC.
 10 Chatham Center South, Suite 100
 Savannah, GA 31405
 Ph: (912) 252-6533
 Fax: (912) 253-4890
 savemal@emc-eng.com
 www.emc-eng.com

EMC
 CIVIL
 MARINE
 ENVIRONMENTAL

ALBANY • ATLANTA • AUGUSTA • BRUNSWICK • COLUMBUS
 SAVANNAH • STATESBORO • THOMASTON • VALDOSTA • WARNER ROBINS

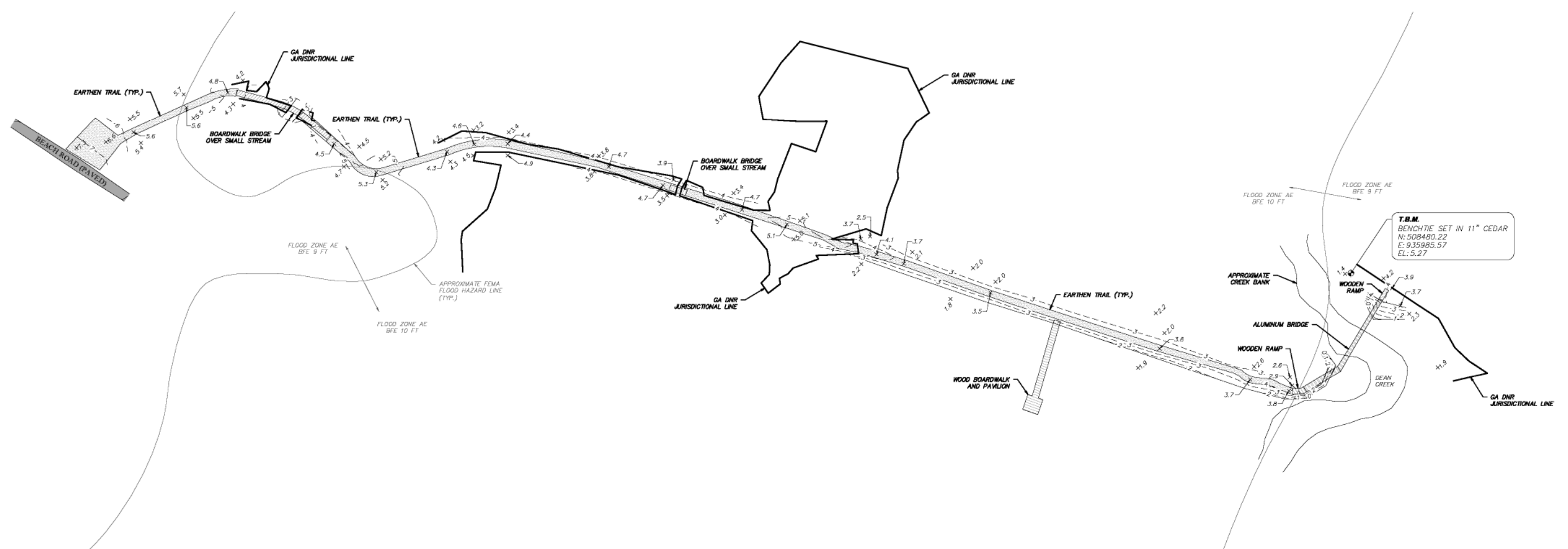

SURVEYOR'S CERTIFICATION

This Topographic Survey was prepared in conformity with The Technical Standards for Surveys in Georgia as set forth in the Rules of the Georgia Board of Registration for Professional Engineers and Land Surveyors and as defined in Rule 180-07-.07. The certification extends only to the topographic aspects of this survey. This topographic survey does not constitute a boundary survey and is not to be recorded.

Jimmy R. Toole
 REG. L. S. LIC. NO. 31919
 DATE: 11/16/2022

SURVEY NOTES

- Horizontal Datum is Georgia State Plane Coordinate System of 1985, East Zone, North American Datum of 1983 (NAD83).
- Vertical Datum is North American Vertical Datum of 1988 (NAVD88).
- Basis of Bearings, Horizontal Control, Vertical Control and some spot elevations were obtained utilizing GPS (global positioning systems). The equipment used to obtain this data was a Champion TKO receiver (RTK Accuracy (Horizontal: 1cm + 1ppm RMS) (Vertical: 2cm + 1ppm RMS)) with a Scepter II data collector receiving RTK corrections via a Verizon Jetpack MIFI 6620L from the eGPS Solutions Real Time Network. The technique used was RTK corrected measurements from a Trimble VRS Real Time Network operated by eGPS Solutions, Inc.
- This survey was prepared without the benefit of an abstract of title. Subject and adjacent property owners' deed references were provided by EMC Engineering Services, Inc. and are not guaranteed as to accuracy or completeness.
- Locations are accurate only where dimensioned.
- This property is located in Zone AE, a Special Flood Hazard Area per the Federal Emergency Management Agency's Flood Insurance Rate Map No. 13191C0320E; Effective Date: August 2, 2018. The flood hazard lines as shown on this plan have been taken digitally from <http://hazards-fema.maps.arcgis.com>, and have not been verified in the field by EMC Engineering Services, Inc.
- No person may copy, reproduce, distribute or alter this plan in whole or in part without the written permission of EMC Engineering Services, Inc.
- The term "Certification" as used in Rule 180-6-.05 (2) and (3) and relating to professional engineering or land surveying services, as defined in O.C.G.A. 43-15-2 (6) and (11), shall mean a signed statement based upon facts and knowledge known to the registrant at the time of the survey and is not a guarantee or warranty, either expressed or implied.
- This survey is valid only if print has the original signature of the surveyor.
- This Survey complies with both the rules of the Georgia Board of Registration for Professional Engineers and Land Surveyors and the Official Code of Georgia Annotated (OCGA) 15-6-67, in that where a conflict exists between those two sets of specifications, the requirements of law prevail.
- This Topographic Survey was prepared in conformity with The Technical Standards for Surveys in Georgia as set forth in the Rules of the Georgia Board of Registration for Professional Engineers and Land Surveyors and as defined in Rule 180-07-.07. The certification extends only to the topographic aspects of this survey. This topographic survey does not constitute a boundary survey and is not to be recorded.
- There was no evidence of recent earth moving work, building construction, or building additions observed in the process of conducting the fieldwork.
- There were no proposed changes in street right of way lines made available to the surveyor by the controlling jurisdiction. There was no evidence of recent street or sidewalk construction or repairs observed in the process of conducting the fieldwork.
- There were no wetland delineation markers observed in the process of conducting the fieldwork.

SURVEY DATA

Equipment used: Topcon PS 103A
 Champion TKO GPS/eGPS Network

Field Work Completed on: 09/22/2022

A TOPOGRAPHIC SURVEY OF
THE SAPELO ISLAND NATURE TRAIL
 1312TH G. M. DISTRICT
 SAPELO ISLAND, MCINTOSH COUNTY, GEORGIA

Prepared for:
 Freedman Engineering Group

PROJECT NO.: 22-0020
 DRAWN BY: SMB
 DESIGNED BY:
 SURVEYED BY: JEH
 SURVEY DATE: 09/22/2022
 CHECKED BY: JRT
 SCALE: 1" = 50'
 DATE: 11/03/2022

SHEET 1
 OF 1

PERMIT DRAWINGS

DEAN CREEK NATURE TRAIL IMPROVEMENTS SAPELO ISLAND, GEORGIA

OWNER'S REPRESENTATIVE

JOEL GRIFFIN
SOUTHERN REGION ENGINEERING
AND CONSTRUCTION
912-381-2511
JOEL.GRIFFIN@DNR.GA.GOV

CIVIL ENGINEER

DAVID FREEDMAN, PE, LEED AP-BD&C
FREEDMAN ENGINEERING GROUP
1000 WHITLOCK AVENUE
SUITE 320, #218
MARIETTA, GA 30064
770-851-3175
Davidf@Freedmanengineering.com

LANDSCAPE ARCHITECT

MICHAEL KIDD, ASLA, LEED AP
ROOT DESIGN STUDIO
3469 LAWRENCEVILLE HIGHWAY
SUITE 204
TUCKER, GEORGIA 30084
(404) 895-2253
MKidd@RootDStudio.com

STRUCTURAL ENGINEER

EMC ENGINEERING SERVICES, INC.
1211 MERCHANT WAY, SUITE 201
STATESBORO, GEORGIA, 30458
(912) 764- 7022
STATESBORO@EMC-ENG.COM



Know what's below.
Call before you dig.

24hr. Contact

JOEL GRIFFIN
912-381-2511

FOR THE

GEORGIA DEPARTMENT OF NATURAL RESOURCES
ENGINEERING AND CONSTRUCTION
#2 MARTIN LUTHER KING, JR. DRIVE, SUITE 1352
ATLANTA, GA 30334
(404) 656-6531

MAY, 2023

DRAWING INDEX

- C-1 COVER SHEET
- C-2 EXISTING CONDITIONS
- C-3 SITE PLAN KEY MAP
- C-4 SITE PLAN
- C-5 SITE PLAN
- C-6 CAUSEWAY SECTIONS
- C-7 BOARDWALK PROFILES
- C-8 CONSTRUCTION DETAILS
- C-9 CONSTRUCTION DETAILS
- C-10 CONSTRUCTION DETAILS
- C-11 CONSTRUCTION DETAILS
- C-12 CONSTRUCTION DETAILS
- C-12 CONSTRUCTION DETAILS
- C-13 CONSTRUCTION DETAILS
- C-14 EROSION, SEDIMENTATION, AND CONTROL PLAN
- C-15 EROSION, SEDIMENTATION, AND CONTROL DETAILS AND NOTES
- C-16 EROSION, SEDIMENTATION, AND CONTROL DETAILS AND NOTES
- C-17 STRUCTURAL PLATFORM FRAMING PLANS
- C-18 STRUCTURAL DETAILS, ELEVATIONS, AND NOTES



DISTURBED AREA: 0.72 ACRE

CERTIFICATION - ES&PC DESIGN PROFESSIONAL
David M. Freedman
5/16/2023
DAVID FREEDMAN
P.E. - LICENSE NO. 14392, GSWCC LEVEL II CERTIFICATION NO. 66474

GSWCC GEORGIA SOIL AND WATER CONSERVATION COMMISSION
David M. Freedman
Level II Certified Design Professional
CERTIFICATION NUMBER 0000066474
ISSUED: 06/22/2021 EXPIRES: 06/22/2024

FREEDMAN ENGINEERING GROUP
David Freedman, PE, LEED AP-BD&C
1000 Whitlock Avenue
Suite 320, #218
Marietta, GA 30064
(770) 851-3175
Davidf@Freedmanengineering.com



Date: 05/16/2023
Project No:
Drawn By: MW
Checked By: DF

DEAN CREEK NATURE TRAIL IMPROVEMENTS
GEORGIA DEPARTMENT OF NATURAL RESOURCES
#2 MARTIN LUTHER KING, JR. DRIVE, SUITE 1352
ATLANTA, GA 30334

Revisions:

NO.	DATE	DESCRIPTION
1	11/20/2023	UPDATED TOPO

Sheet Title:
COVER SHEET

Sheet No:
C-1

RELEASED FOR CONSTRUCTION

FREEDMAN ENGINEERING GROUP

David Freedman, PE, LEED AP-BD&C
1000 Whitlock Avenue
Suite 320, #218
Marietta, GA 30064
(770) 851-3175
David@Freedmanengineering.com

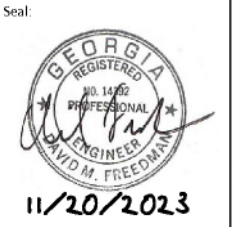

Date: 05/16/2023
Project No:
Drawn By: MW
Checked By: DF

DEAN CREEK NATURE TRAIL IMPROVEMENTS
GEORGIA DEPARTMENT OF NATURAL RESOURCES
#2 MARTIN LUTHER KING, JR. DRIVE, SUITE 1352
ATLANTA, GA 30334

Revisions:

NO.	DATE	DESCRIPTION
1	11/20/2023	UPDATED TOPO

Sheet Title:
EXISTING CONDITIONS

Sheet No:
C-2

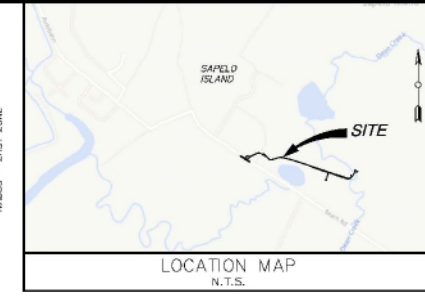

NO.	REVISION DESCRIPTION	DATE



EMC ENGINEERING SERVICES, INC.
10 Chatham Center South, Suite 100
Savannah, GA 31405
PH: (912) 232-5535
savannah@emc-eng.com
www.emc-eng.com



A TOPOGRAPHIC SURVEY OF
THE SAPELO ISLAND NATURE TRAIL
1312TH G. M. DISTRICT
SAPELO ISLAND, MCINTOSH COUNTY, GEORGIA
Prepared for:
Freedman Engineering Group

PROJECT NO: 22-0220
DRAWN BY: SMB
DESIGNED BY:
SURVEY DATE: 09/22/2022
CHECKED BY: JRT
SCALE: 1" = 50'
DATE: 11/03/2022

SHEET
1
OF 1

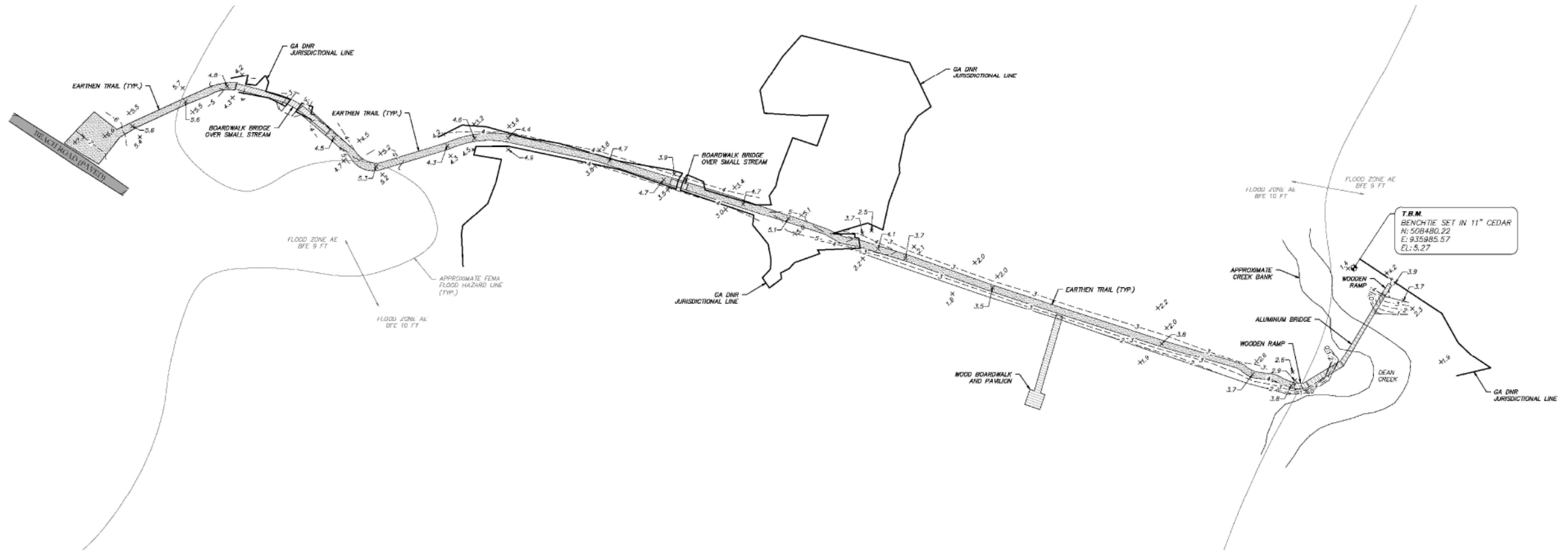

SURVEY NOTES

- Horizontal Datum is Georgia State Plane Coordinate System of 1985, East Zone, North American Datum of 1983 (NAD83).
- Vertical Datum is North American Vertical Datum of 1988 (NAVD88).
- Base of Bearings, Horizontal Control, Vertical Control and some spot elevations were obtained utilizing GPS (global positioning systems). The equipment used to obtain this data was a Champion TKO receiver (RTK Accuracy (Horizontal: 1cm + 1ppm RMS) (Vertical: 3cm + 1ppm RMS)) with a Scepter II data collector receiving RTK corrections via a Verizon Jetpack (MIFI) 3620L from the eGPS solutions Real Time Network. The technique used was RTK corrected measurements from a Trimble VRS Real Time Network operated by eGPS Solutions, Inc.
- This survey was prepared without the benefit of an abstract of title. Subject and adjacent property owners' deed references were provided by EMC Engineering Services, Inc. and are not guaranteed as to accuracy or completeness.
- Locations are accurate only where dimensioned.
- This property is located in Zone AE, a Special Flood Hazard Area per the Federal Emergency Management Agency's Flood Insurance Rate Map No. 1319100220E; Effective Date: August 2, 2018. The flood hazard lines as shown on this plat have been taken digitally from <http://hazards.fema.maps.arcgis.com>, and have not been verified in the field by EMC Engineering Services, Inc.
- No person may copy, reproduce, distribute or alter this plat in whole or in part without the written permission of EMC Engineering Services, Inc.
- The term "Certification" as used in Rule 180-6-.09 (2) and (3) and relating to professional engineering or land surveying services, as defined in O.C.G.A. 43-15-2 (6) and (11), shall mean a signed statement based upon facts and knowledge known to the registrant at the time of the survey and is not a guarantee or warranty, either expressed or implied.
- This survey is valid only if it has the original signature of the surveyor.
- This Survey complies with both the rules of the Georgia Board of Registration for Professional Engineers and Land Surveyors and the Official Code of Georgia Annotated (OCGA) 18-8-87, in that where a conflict exists between those two sets of specifications, the requirements of law prevail.
- This Topographic Survey was prepared in conformity with The Technical Standards for Surveys in Georgia as set forth in the Rules of the Georgia Board of Registration for Professional Engineers and Land Surveyors and as defined in Rule 180-07-.07. The certification extends only to the topographic aspects of this survey. This topographic survey does not constitute a boundary survey and is not to be recorded.
- There was no evidence of recent earth moving work, building construction, or building additions observed in the process of conducting the fieldwork.
- There were no proposed changes in street right of way lines made available to the surveyor by the controlling jurisdiction. There was no evidence of recent street or sidewalk construction or repairs observed in the process of conducting the fieldwork.
- There were no wetland delineation markers observed in the process of conducting the fieldwork.

SURVEY DATA

Equipment used: Topcon PS 103A
Champion TKO GPS/eGPS Network
Field Work Completed on: 09/22/2022

SURVEYOR'S CERTIFICATION



This Topographic Survey was prepared in conformity with The Technical Standards for Surveys in Georgia as set forth in the Rules of the Georgia Board of Registration for Professional Engineers and Land Surveyors and as defined in Rule 180-07-.07. The certification extends only to the topographic aspects of this survey. This topographic survey does not constitute a boundary survey and is not to be recorded.

Jimmy R. Toole
JIMMY R. TOOLE
S.E. REG. L.S. LIC. NO. 3119

11/16/2022
DATE

RELEASED FOR CONSTRUCTION

NOTES

1. CONTRACTOR TO STAKE OUT NEW BOARDWALKS FOR OWNER'S APPROVAL INCLUDING ELEVATIONS.
2. ALL LUMBER/TIMBER TO BE SOUTHERN YELLOW PINE NUMBER 1.
3. ALL LUMBER/TIMBER SHALL BE OF SOUND STOCK, DELIVERED DRY, AND SHALL BE FULLY PROTECTED AT ALL TIMES FROM INJURY AND DAMPNES. SPLIT, BROKEN, OR OTHERWISE DAMAGED PIECES WILL NOT BE ALLOWED IN THE WORK.
4. LUMBER/TIMBER SHALL BE TREATED WITH PRESERVATIVES TO THE FOLLOWING REQUIREMENTS IN ACCORDANCE WITH AMERICAN WOOD PROTECTION ASSOCIATION (AWPA) STANDARD U1 OR ICC-ES EVALUATION REPORTS:
 - a. 6" BY 6" OR 8" DIAMETER PILES AND 8" BY 8" TIMBERS - USE CATEGORY UCSB, 2.5 PCF CCA.
 - b. STRUCTURAL LUMBER FOR BOARDWALKS AND STAIRS - 8" X 8", 2" X 12", 2" X 10", 6" X 6", 4" X 4" - USE CATEGORY UC4B, 0.60 PCF CCA.
 - c. HANDRAIL SYSTEM INCLUDING 2" X 8" TOP RAIL, PLATFORM, AND BOARDWALK CURBING - 4" X 6", 2" X 6", 2" X 4", 4" BY 4" - USE CATEGORY UC4B, 0.31 PCF CA-C.
5. ALL TREATMENT SHALL BE PERFORMED IN ACCORDANCE WITH THE REQUIREMENTS OF THE STANDARD SPECIFICATIONS OF THE AMERICAN WOOD PROTECTION ASSOCIATION FOR TREATING WOOD. APPLY A HEAVY COAT OF THE SAME PRESERVATIVE USED IN TREATING TO ALL SURFACES CUT AFTER TREATMENT.
6. HURRICANE ANCHORS TO BE SIMPSON H2.5ASS (STAINLESS STEEL) WITH STAINLESS STEEL NAILS AS RECOMMENDED BY ANCHOR MANUFACTURER.
7. ALL HARDWARE (BOLTS, SCREWS, NAILS, ETC.) TO BE STAINLESS STEEL.
8. CONNECTING HARDWARE TO BE AS FOLLOWS:
 - a. DECKING TO STRINGERS - 3 - 3" STAINLESS STEEL SCREWS AT EACH STRINGER
 - b. 2" X 6" CURB TO DECKING - 3" STAINLESS STEEL SCREWS EVERY 12"
 - c. 4" X 6" CURB THROUGH 2" X 6" TO DECKING - 5/8" DIAMETER STAINLESS STEEL BOLTS EVERY 18". COUNTERSINK BOLTS SO THEY ARE FLUSH WITH WOOD SURFACE.
 - d. BLOCKING - 3" STAINLESS STEEL SCREWS
 - e. STRINGER SPLICE PLATE - TWO 5/8" DIAMETER STAINLESS STEEL BOLTS WITH 3" FLAT WASHERS AT EACH SIDE OF JOINT
 - f. SPLIT PILE CAPS TO PILES - TWO 3/4" DIAMETER STAINLESS STEEL BOLTS WITH 3" FLAT WASHERS.
 - g. RAILINGS - 3" STAINLESS STEEL SCREWS
 - h. RAIL POSTS - TWO 3/4" DIAMETER STAINLESS STEEL BOLTS WITH 3" FLAT WASHERS.

9. FOR BOLTED WORK, BORE HOLES OF SAME DIAMETER AS BOLTS AND DRIVE BOLTS INTO PLACE.
10. WASHERS SHALL BE PROVIDED UNDER ALL BOLT HEADS AND NUTS.
11. BOLTS SHALL BE STANDARD HEX HEAD.
12. DECKING SHALL BE INSTALLED WITH THE BARK SIDE UP TO PREVENT CUPPING.
13. EDGES OF CURBS AND RAILS SHALL BE CHAMFERED. HANDRAILS AND ALL OTHER ACCESSIBLE SURFACES SHALL BE GROUND SMOOTH WITH NO SHARP EDGES OR CORNERS.
14. BOARDWALK HEIGHT WITHOUT RAILINGS, TOP OF DECK TO GROUND SURFACE, CANNOT EXCEED THIRTY (30) INCHES.
15. DESIGN IS BASED ON A LIVE LOAD OF 85 POUNDS PER SQUARE FOOT.
16. ALL DEMOLITION MATERIALS TO BE REMOVED FROM THE SITE AND PROPERLY DISPOSED OF.
17. ALL POSTS AND UNDERGROUND ELEMENTS TO BE REMOVED TO BE CUT OFF ONE (1) FOOT BELOW THE GROUND SURFACE.
18. THE OWNER RESERVES THE RIGHT TO RETAIN ANY MATERIALS IDENTIFIED FOR DEMOLITION. THESE MATERIALS TO BE NEATLY STACKED IN A LOCATION DESIGNATED BY THE OWNER.
19. SUBMITTALS ARE REQUIRED ON ALL MATERIALS TO BE INCORPORATED INTO THE WORK.
20. EXISTING SIGNAGE ALONG TRAIL, WHEN IMPACTED BY PROPOSED WORK, TO BE REMOVED, STORED, AND REPLACED IN THE SAME LOCATION UPON COMPLETION OF THE WORK.

SITE PLAN NOTES:

1. CONSTRUCTION ACCESS PATH TO BE 14 FEET WIDE, 7 FEET ON EITHER SIDE OF THE BOARDWALK CENTERLINE. MATS TO BE PLACED ON THE GROUND IN ALL AREAS WITHIN THE DNR JURISDICTIONAL LINE.
2. HIGH TIDE LINE ELEVATION = 5.32.
3. MEANT HIGH WATER ELEVATION = 2.9.

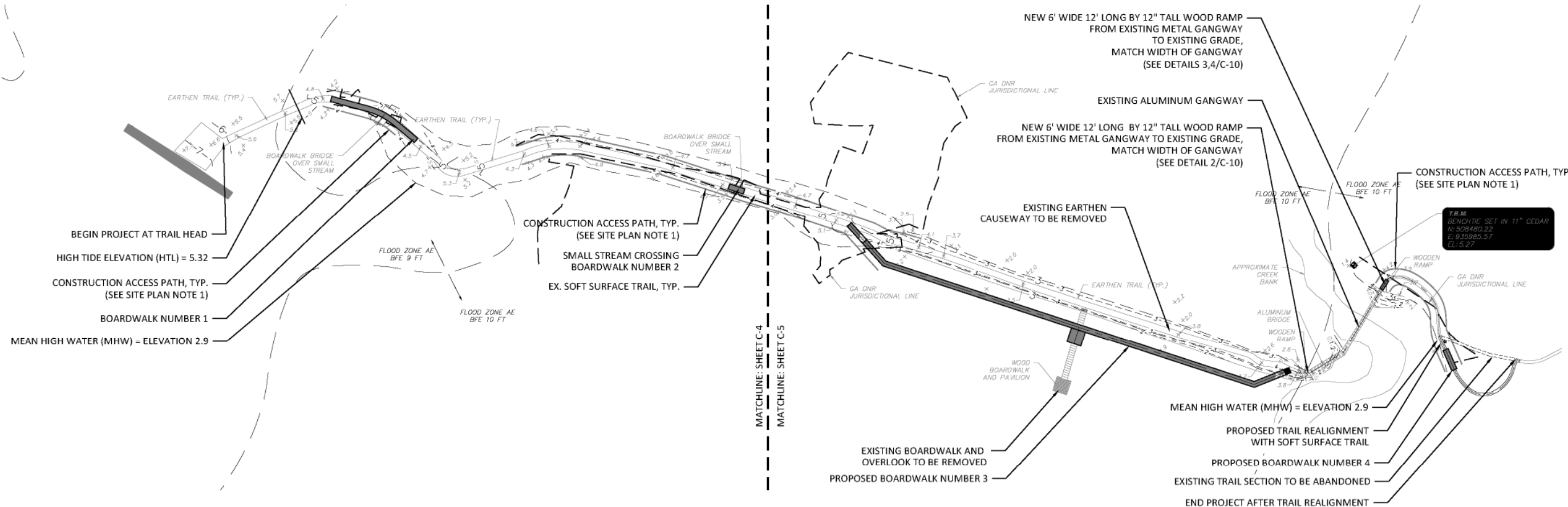

FREEDMAN ENGINEERING GROUP

David Freedman, PE, LEED AP-BD&C
 1000 Whitlock Avenue
 Suite 320, #218
 Marietta, GA 30064
 (770) 851-3175
 David@Freedmanengineering.com



Date: 05/16/2023
 Project No:
 Drawn By: MW
 Checked By: DF

DEAN CREEK NATURE TRAIL IMPROVEMENTS
 GEORGIA DEPARTMENT OF NATURAL RESOURCES
 #2 MARTIN LUTHER KING, JR. DRIVE, SUITE 1352
 ATLANTA, GA 30334

Revisions:

NO.	DATE	DESCRIPTION
1	11/20/2023	UPDATED TOPO

Sheet Title:
SITE PLAN KEY MAP

Sheet No:
C-3

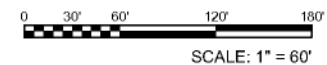

RELEASED FOR CONSTRUCTION

- SITE PLAN NOTES:**
- CONSTRUCTION ACCESS PATH TO BE 14 FEET WIDE, 7 FEET ON EITHER SIDE OF THE BOARDWALK CENTERLINE. MATS TO BE PLACED ON THE GROUND IN ALL AREAS WITHIN THE DNR JURISDICTIONAL LINE.
 - HIGH TIDE LINE ELEVATION = 5.32.
 - MEANT HIGH WATER ELEVATION = 2.9.

FREEDMAN ENGINEERING GROUP

David Freedman, PE, LEED AP-BD&C
 1000 Whitlock Avenue
 Suite 320, #218
 Marietta, GA 30064
 (770) 851-3175
 David@Freedmanengineering.com

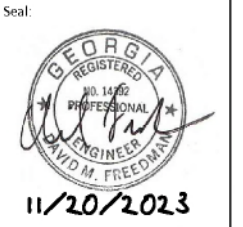

Date: 05/16/2023
 Project No:
 Drawn By: MW
 Checked By: DF

**DEAN CREEK
 NATURE TRAIL IMPROVEMENTS**

GEORGIA DEPARTMENT OF NATURAL RESOURCES
 #2 MARTIN LUTHER KING, JR. DRIVE, SUITE 1352
 ATLANTA, GA 30334

Revisions:

NO.	DATE	DESCRIPTION
1	11/20/2023	UPDATED TOPO

Sheet Title:
SITE PLAN

Sheet No:
C-4

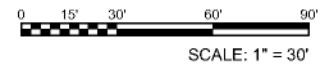
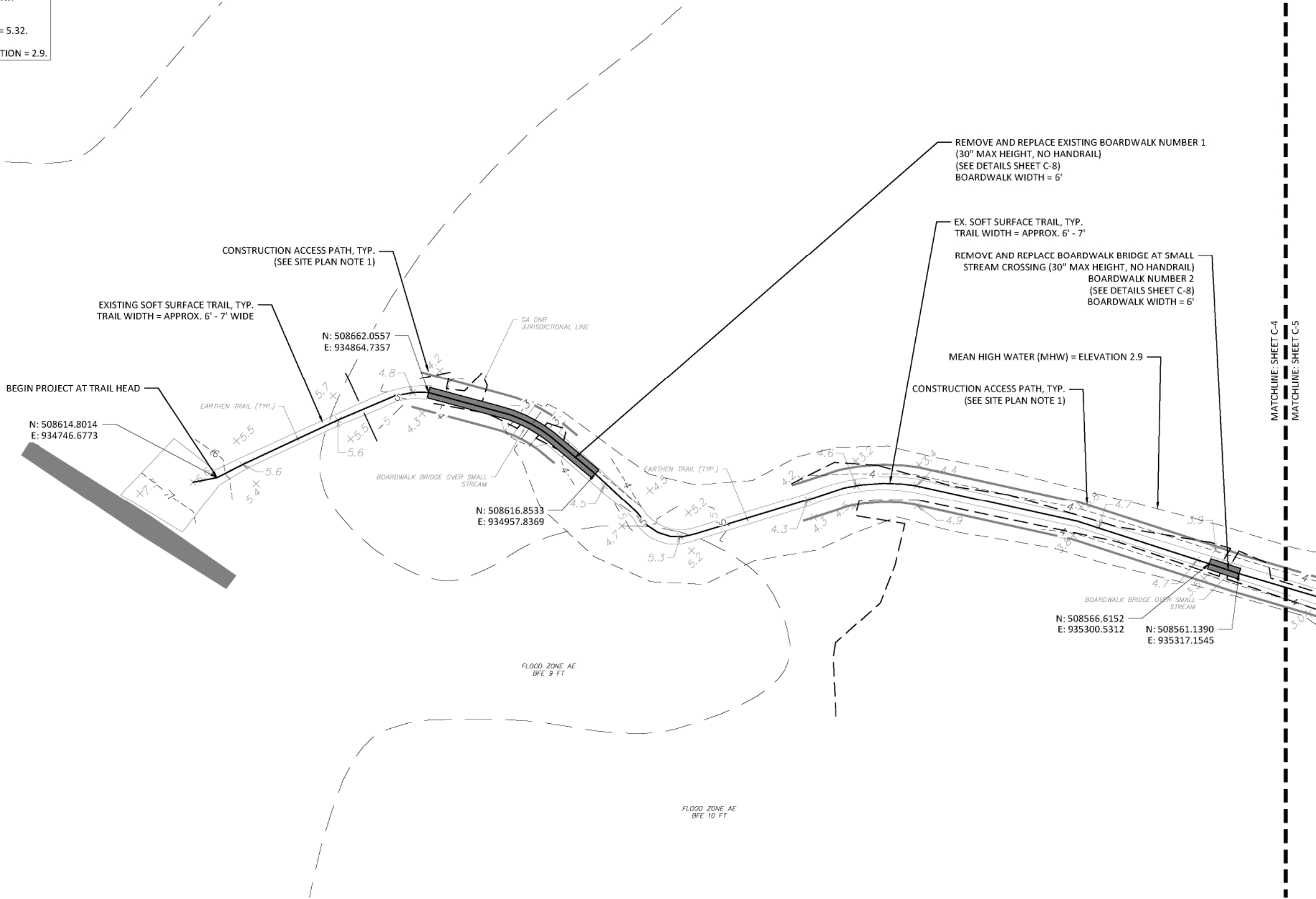

RELEASED FOR CONSTRUCTION



- SITE PLAN NOTES:**
- CONSTRUCTION ACCESS PATH TO BE 14 FEET WIDE, 7 FEET ON EITHER SIDE OF THE BOARDWALK CENTERLINE. MATS TO BE PLACED ON THE GROUND IN ALL AREAS WITHIN THE DNR JURISDICTIONAL LINE.
 - HIGH TIDE LINE ELEVATION = 5.32.
 - MEANT HIGH WATER ELEVATION = 2.9.

FREEDMAN ENGINEERING GROUP

David Freedman, PE, LEED AP-BD&C
 1000 Whitlock Avenue
 Suite 320, #218
 Marietta, GA 30064
 (770) 851-3175
 David@Freedmanengineering.com

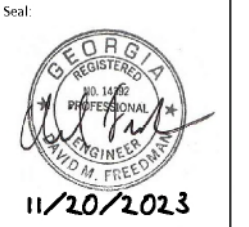

Date: 05/16/2023
 Project No:
 Drawn By: MW
 Checked By: DF

DEAN CREEK NATURE TRAIL IMPROVEMENTS
 GEORGIA DEPARTMENT OF NATURAL RESOURCES
 #2 MARTIN LUTHER KING, JR. DRIVE, SUITE 1352
 ATLANTA, GA 30334

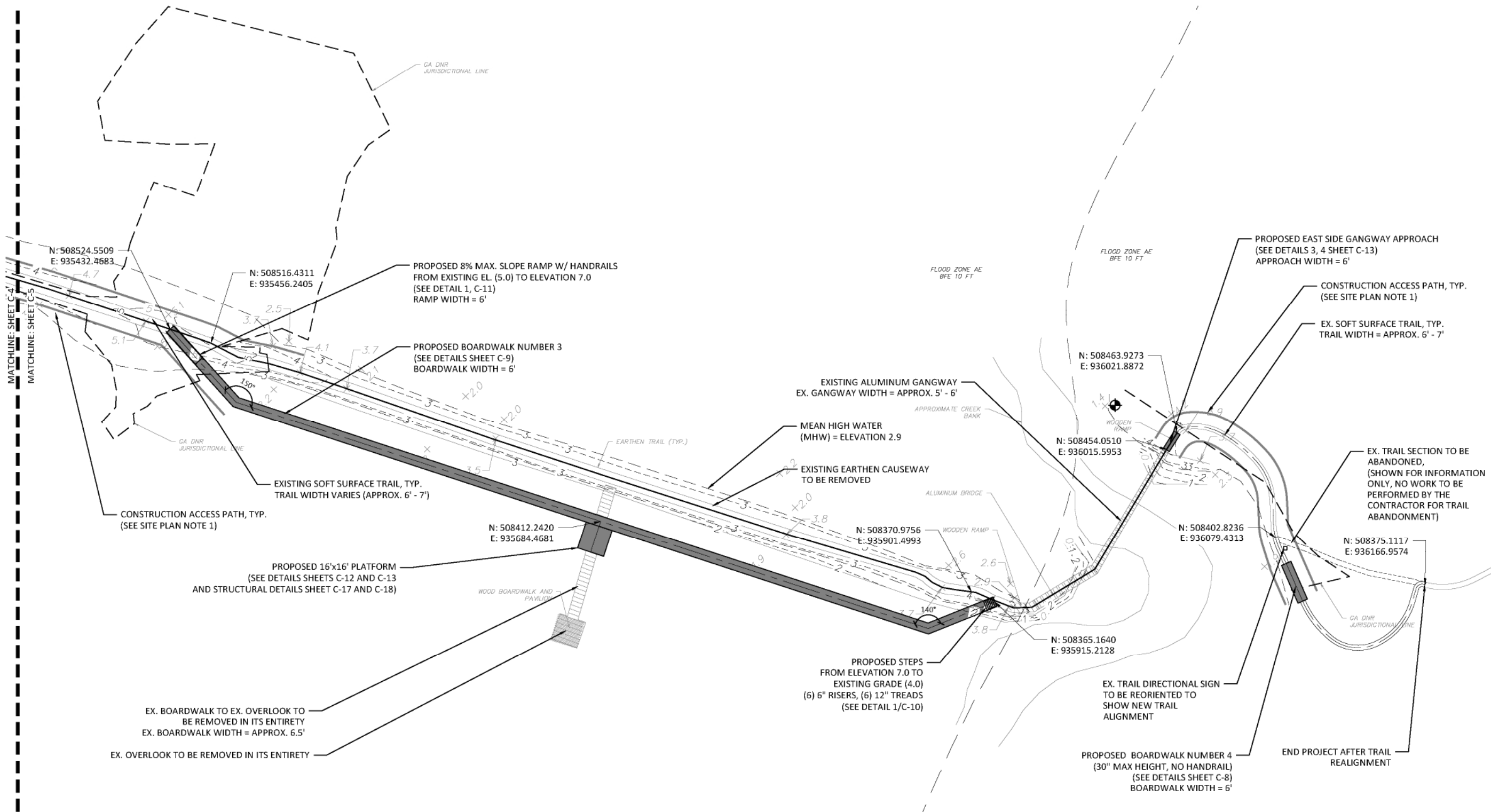

Revisions:

NO.	DATE	DESCRIPTION
1	11/20/2023	UPDATED TOPO

Sheet Title:
SITE PLAN

Sheet No:
C-5

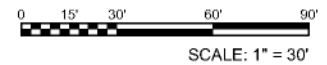

RELEASED FOR CONSTRUCTION

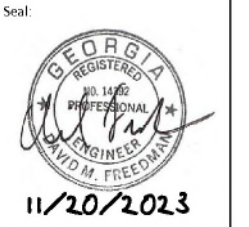

Date: 05/16/2023
Project No:
Drawn By: MW
Checked By: DF

**DEAN CREEK
NATURE TRAIL IMPROVEMENTS**
GEORGIA DEPARTMENT OF NATURAL RESOURCES
#2 MARTIN LUTHER KING, JR. DRIVE, SUITE 1352
ATLANTA, GA 30334

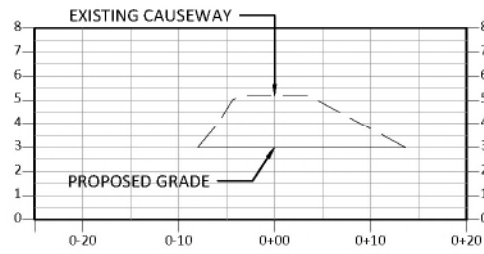

CAUSEWAY REMOVAL SECTION 1

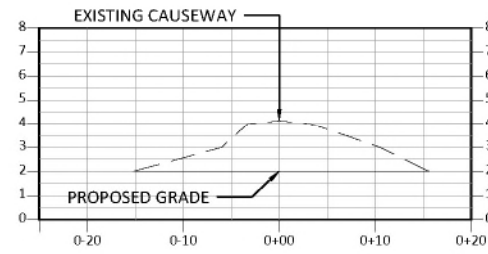

CAUSEWAY REMOVAL SECTION 2

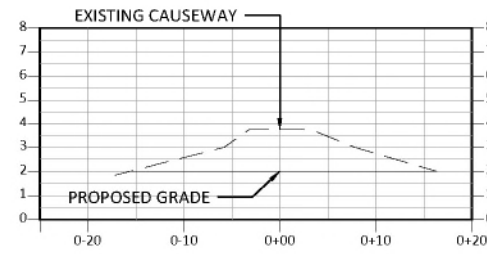

CAUSEWAY REMOVAL SECTION 3

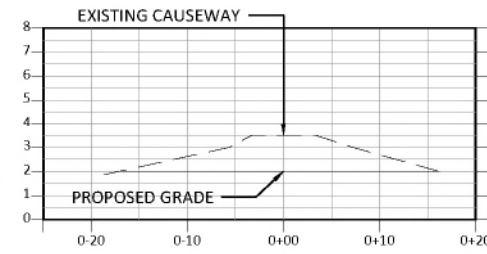

CAUSEWAY REMOVAL SECTION 4

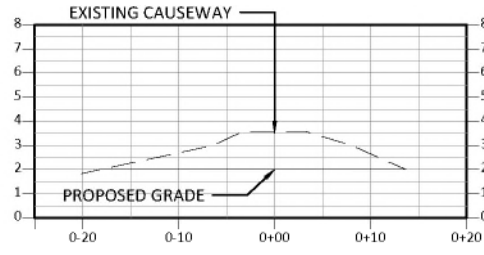

CAUSEWAY REMOVAL SECTION 5

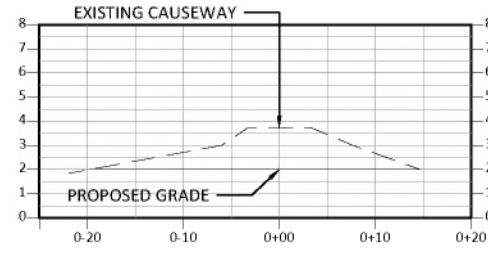

CAUSEWAY REMOVAL SECTION 6

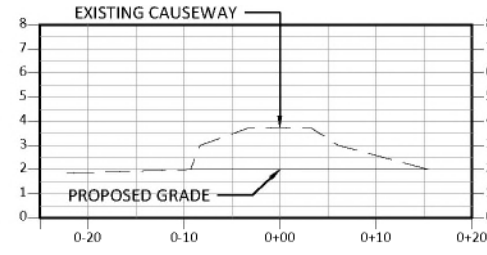

CAUSEWAY REMOVAL SECTION 7

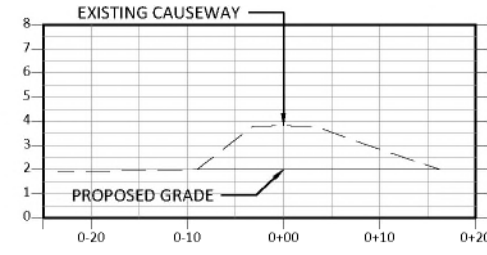

CAUSEWAY REMOVAL SECTION 8

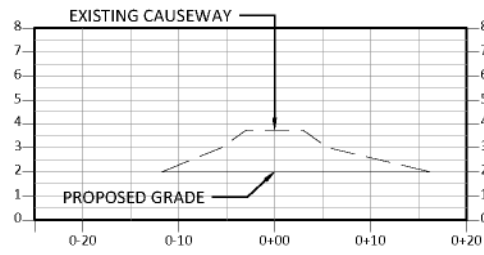

CAUSEWAY REMOVAL SECTION 9

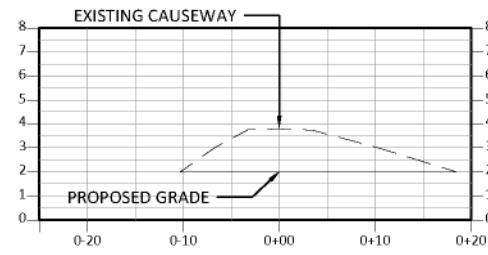

CAUSEWAY REMOVAL SECTION 10

CAUSEWAY SECTIONS
HORIZONTAL SCALE: 1" = 10'-0"
VERTICAL SCALE: 1" = 4'-0"

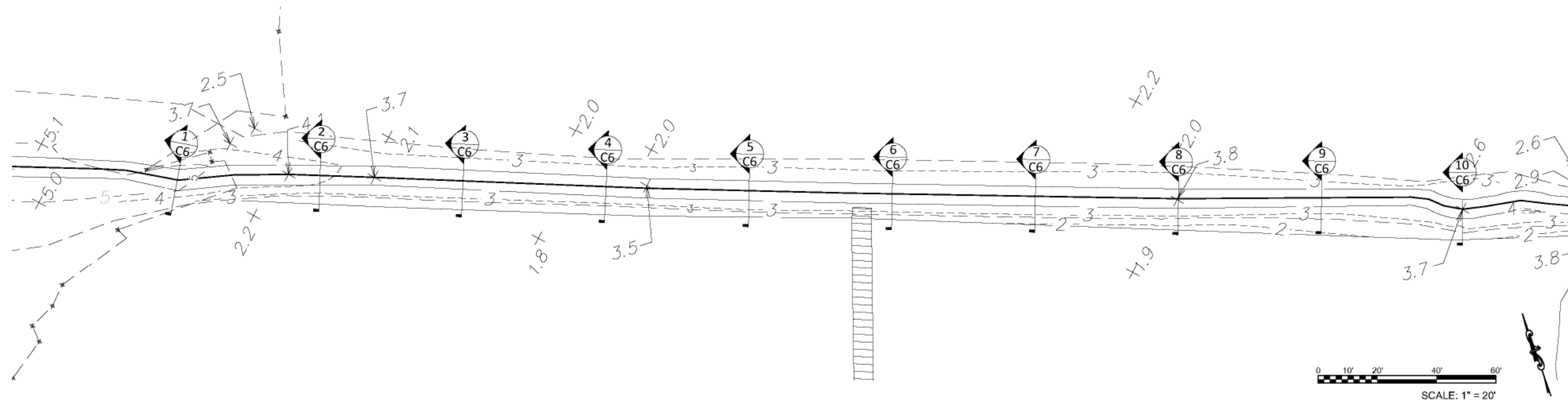

Revisions:

NO.	DATE	DESCRIPTION
1	11/20/2023	UPDATED TOPO

Sheet Title:
CAUSEWAY SECTIONS

Sheet No:
C-6

RELEASED FOR CONSTRUCTION

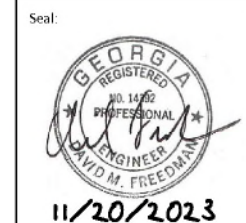

Date: 05/16/2023
Project No:
Drawn By: MW
Checked By: DF

**DEAN CREEK
NATURE TRAIL IMPROVEMENTS**
GEORGIA DEPARTMENT OF NATURAL RESOURCES
#2 MARTIN LUTHER KING, JR. DRIVE, SUITE 1352
ATLANTA, GA 30334

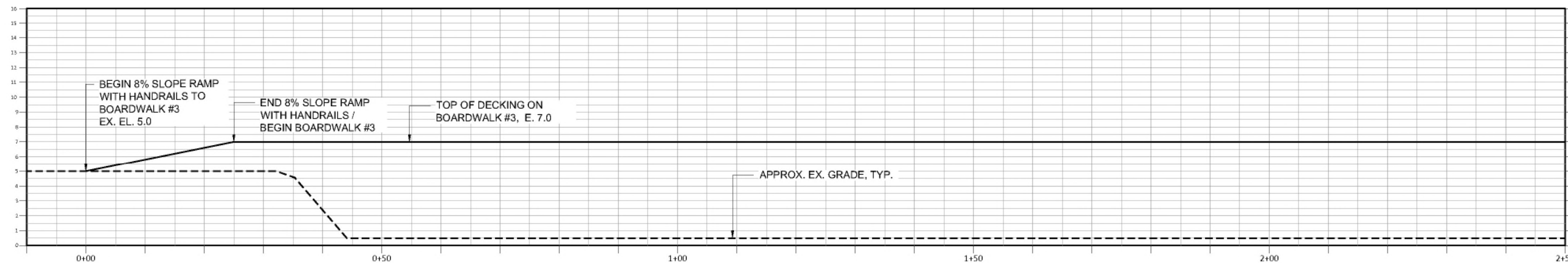

1 BOARDWALK #3 PROFILE: SECTION A

HORIZONTAL SCALE: 1" = 10'-0"
VERTICAL SCALE: 1" = 4'-0"

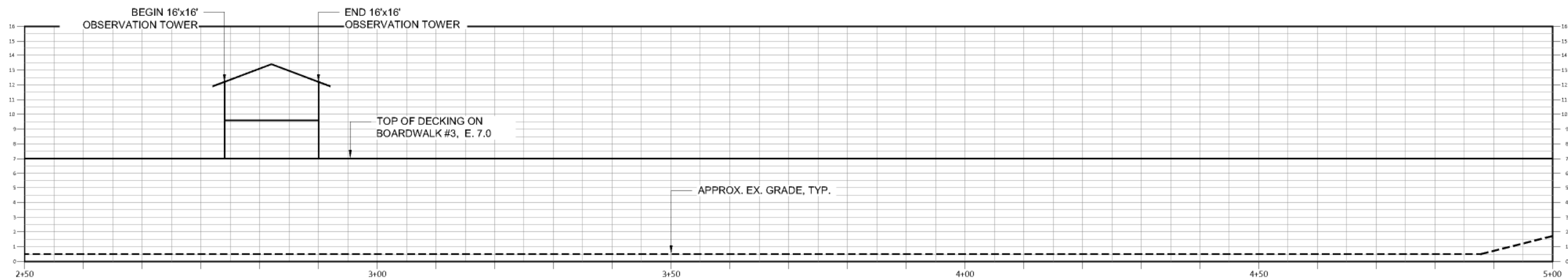

2 BOARDWALK #3 PROFILE: SECTION B

HORIZONTAL SCALE: 1" = 10'-0"
VERTICAL SCALE: 1" = 4'-0"

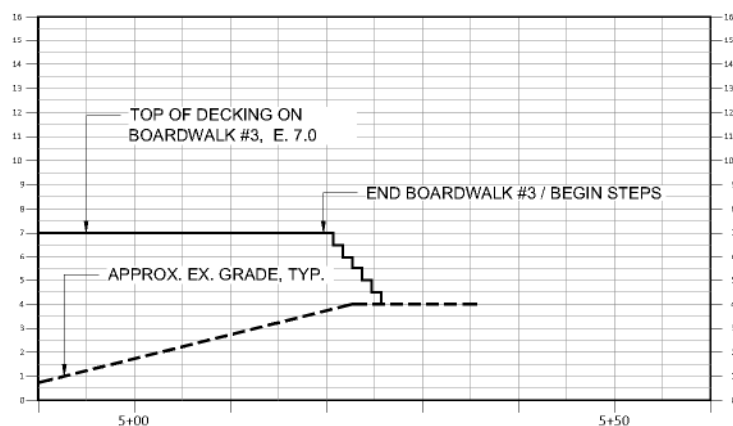

3 BOARDWALK #3 PROFILE: SECTION C

HORIZONTAL SCALE: 1" = 10'-0"
VERTICAL SCALE: 1" = 4'-0"

Revisions:

NO.	DATE	DESCRIPTION
1	11/20/2023	UPDATED TOPO

Sheet Title:
**BOARDWALK
PROFILES**

Sheet No:
C-7

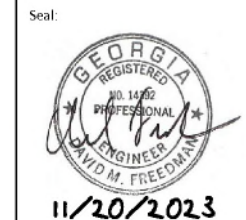

Date: 05/16/2023
Project No:
Drawn By: MW
Checked By: DF

**DEAN CREEK
NATURE TRAIL IMPROVEMENTS**
GEORGIA DEPARTMENT OF NATURAL RESOURCES
#2 MARTIN LUTHER KING, JR. DRIVE, SUITE 1352
ATLANTA, GA 30334

Revisions:

NO.	DATE	DESCRIPTION
1	11/20/2023	UPDATED TOPO

Sheet Title:
**CONSTRUCTION
DETAILS**

Sheet No:
C-8

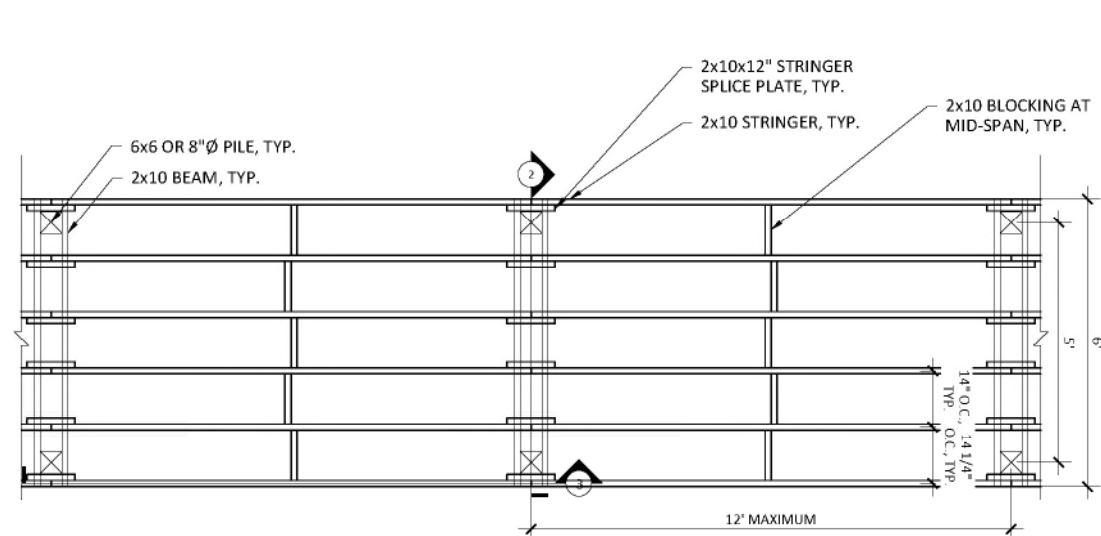

NOTE
BOARDWALK 1 IS 105 FEET LONG.
BOARDWALK 2 IS 18 FEET LONG.
BOARDWALK 4 IS 24 FEET LONG.

1 TYPICAL FRAMING PLAN - BOARDWALKS 1, 2, AND 4 (NO HANDRAIL)
1/2" = 1'-0"

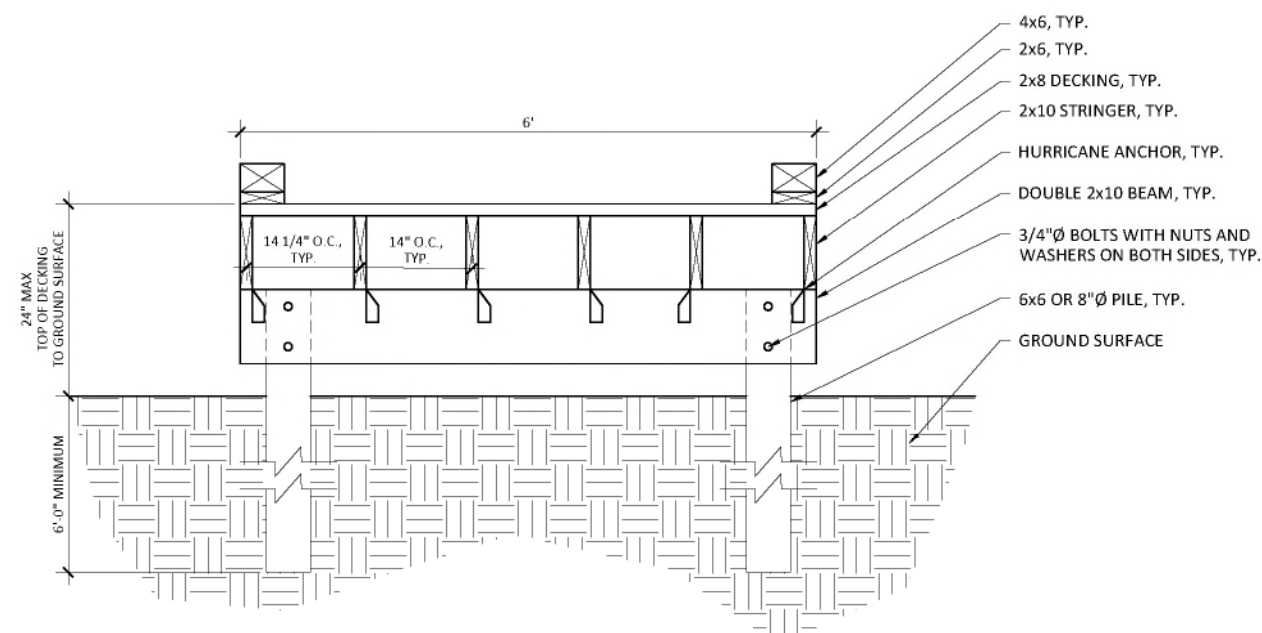

2 TYPICAL CROSS SECTION - BOARDWALKS 1, 2, AND 4 (NO HANDRAIL)
1" = 1'-0"

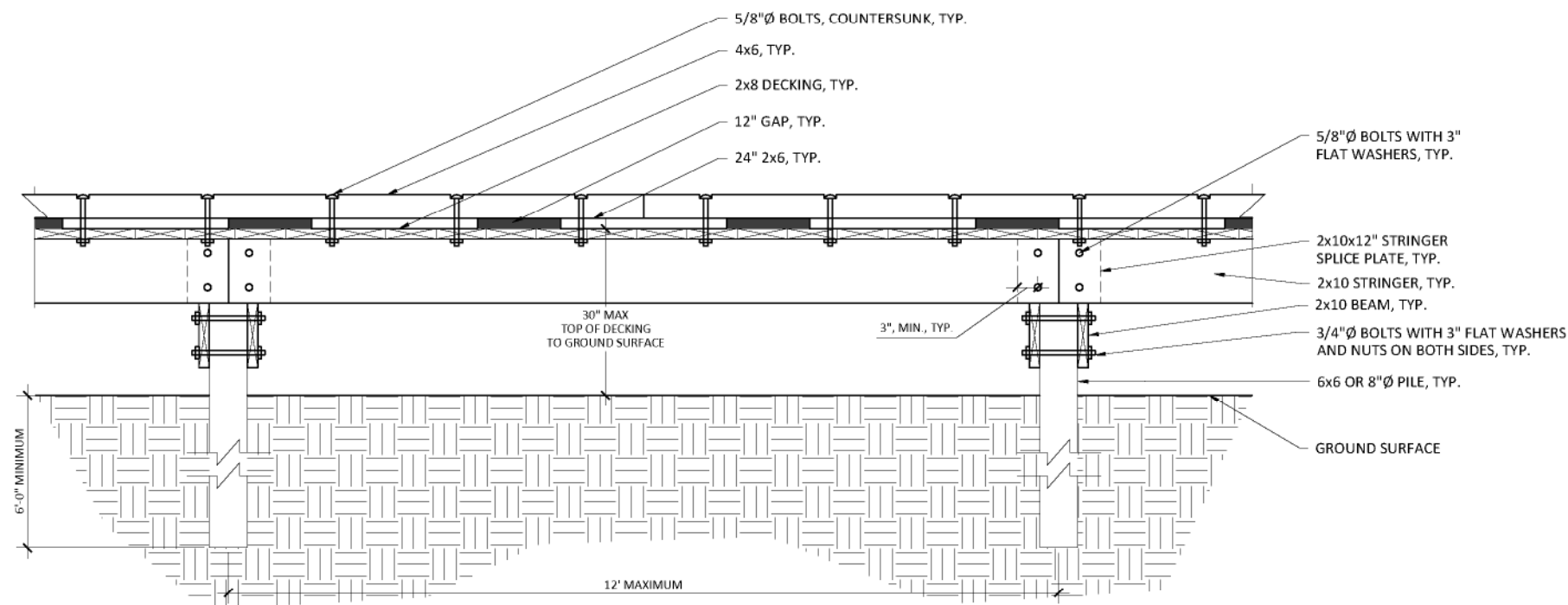

3 TYPICAL PROFILE SECTION - BOARDWALKS 1, 2, AND 4 (NO HANDRAIL)
1" = 1'-0"

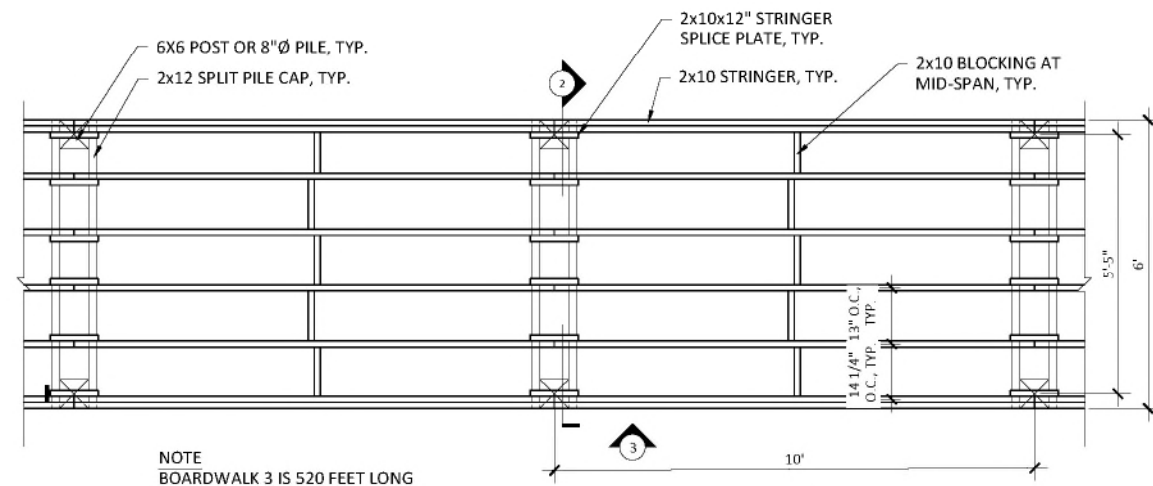

1 BOARDWALK 3 FRAMING PLAN
1/2" = 1'-0"

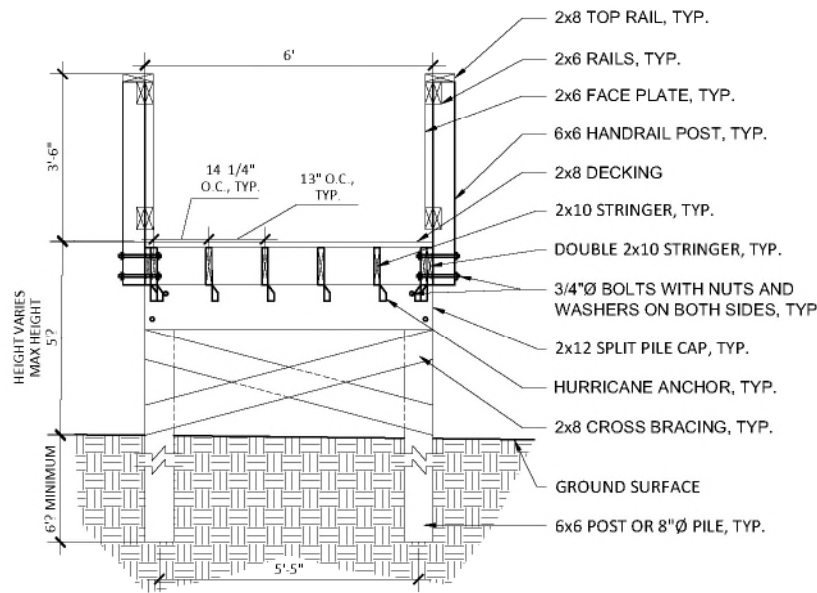

2 BOARDWALK 3 CROSS SECTION
1/2" = 1'-0"

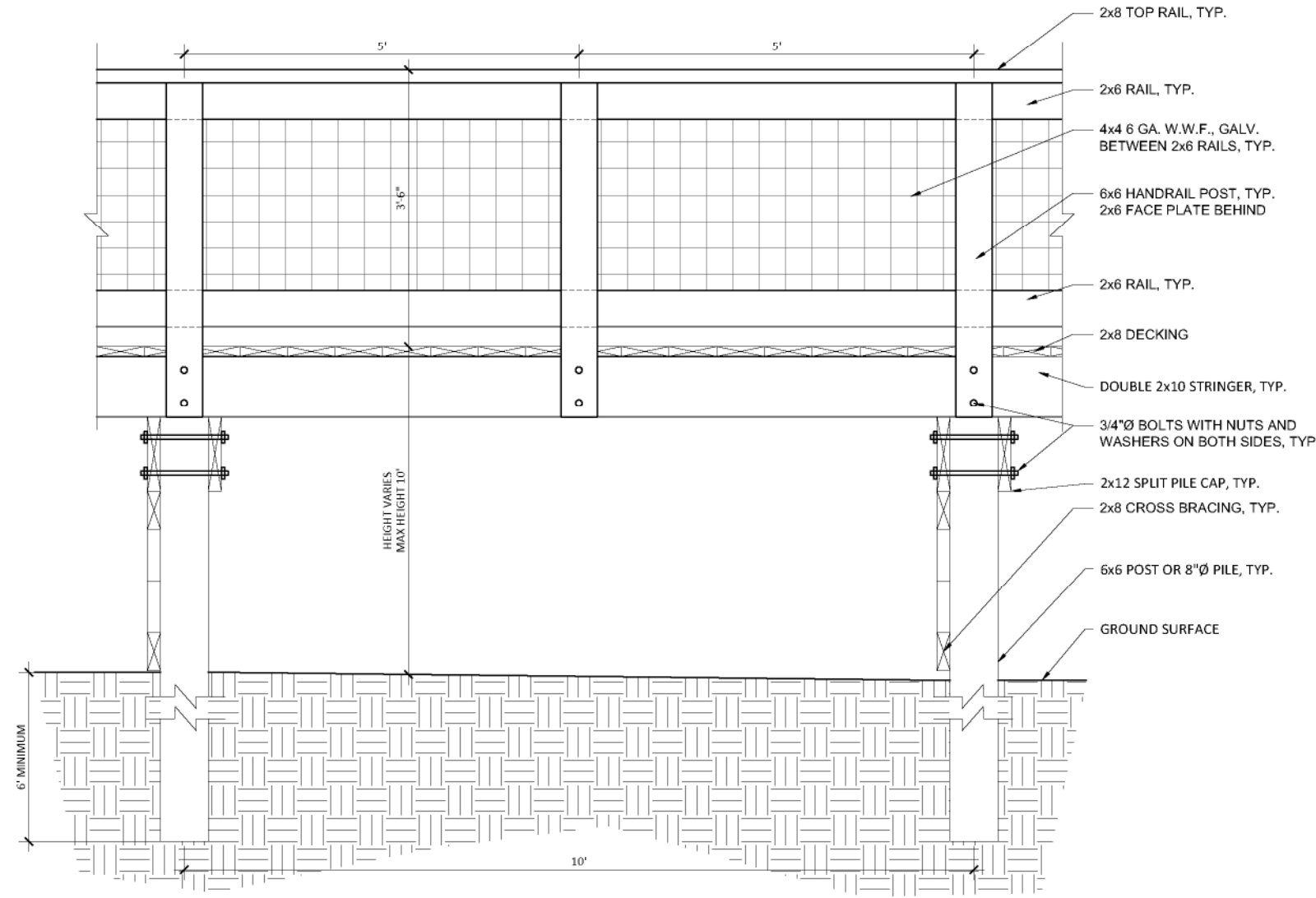

3 TYPICAL PROFILE SECTION - BOARDWALK 3
1" = 1'-0"

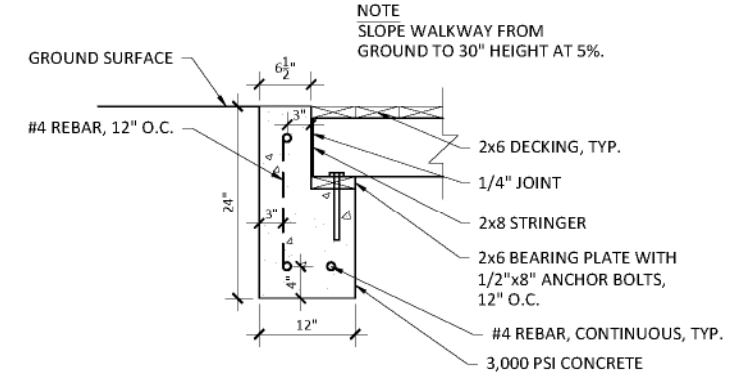

4 ABUTMENT DETAIL
1" = 1'-0"

FREEDMAN ENGINEERING GROUP
David Freedman, PE, LEED AP-BD&C
1000 Whitlock Avenue
Suite 320, #218
Marietta, GA 30064
(770) 851-3175
David@Freedmanengineering.com

Seal:

11/20/2023

Date: 05/16/2023
Project No:
Drawn By: MW
Checked By: DF

DEAN CREEK NATURE TRAIL IMPROVEMENTS
GEORGIA DEPARTMENT OF NATURAL RESOURCES
#2 MARTIN LUTHER KING, JR. DRIVE, SUITE 1352
ATLANTA, GA 30334

Revisions:

NO.	DATE	DESCRIPTION
1	11/20/2023	UPDATED TOPO

Sheet Title:
CONSTRUCTION DETAILS

Sheet No:
C-9

RELEASED FOR CONSTRUCTION

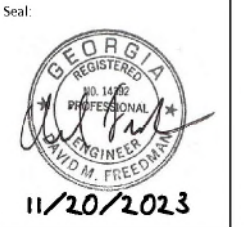

Date: 05/16/2023
Project No:
Drawn By: MW
Checked By: DF

**DEAN CREEK
NATURE TRAIL IMPROVEMENTS**

GEORGIA DEPARTMENT OF NATURAL RESOURCES
#2 MARTIN LUTHER KING, JR. DRIVE, SUITE 1352
ATLANTA, GA 30334

Revisions:

NO.	DATE	DESCRIPTION
1	11/20/2023	UPDATED TOPO

Sheet Title:
**CONSTRUCTION
DETAILS**

Sheet No:
C-10

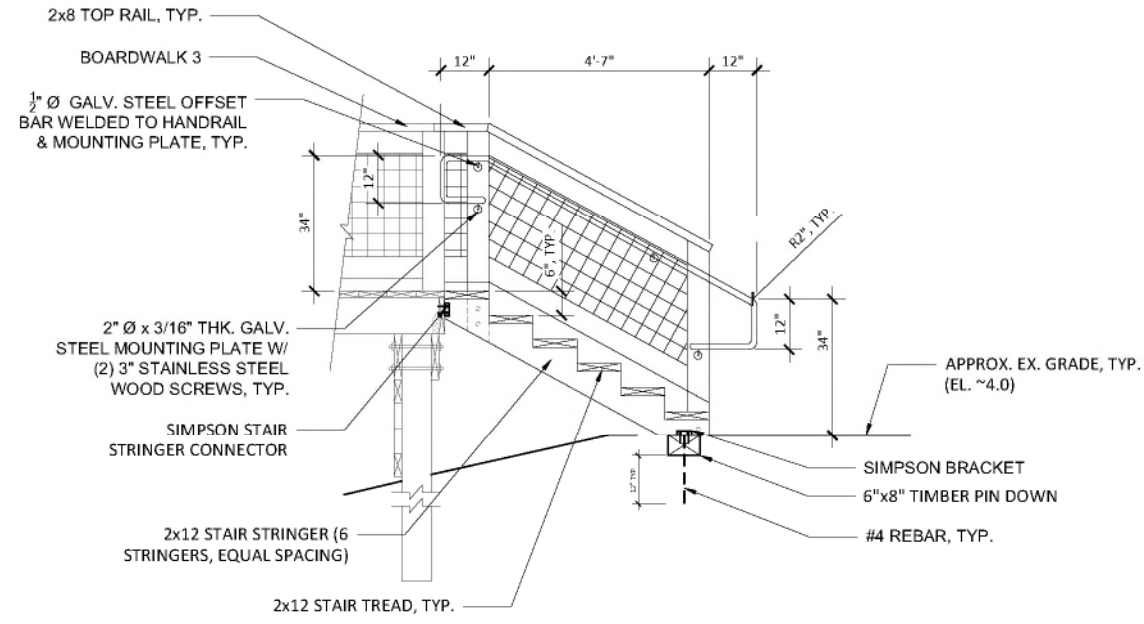

1 PROPOSED STEPS AT END OF BOARDWALK 3 (AT WEST SIDE GANGWAY APPROACH) - SECTION
1/2" = 1'-0"

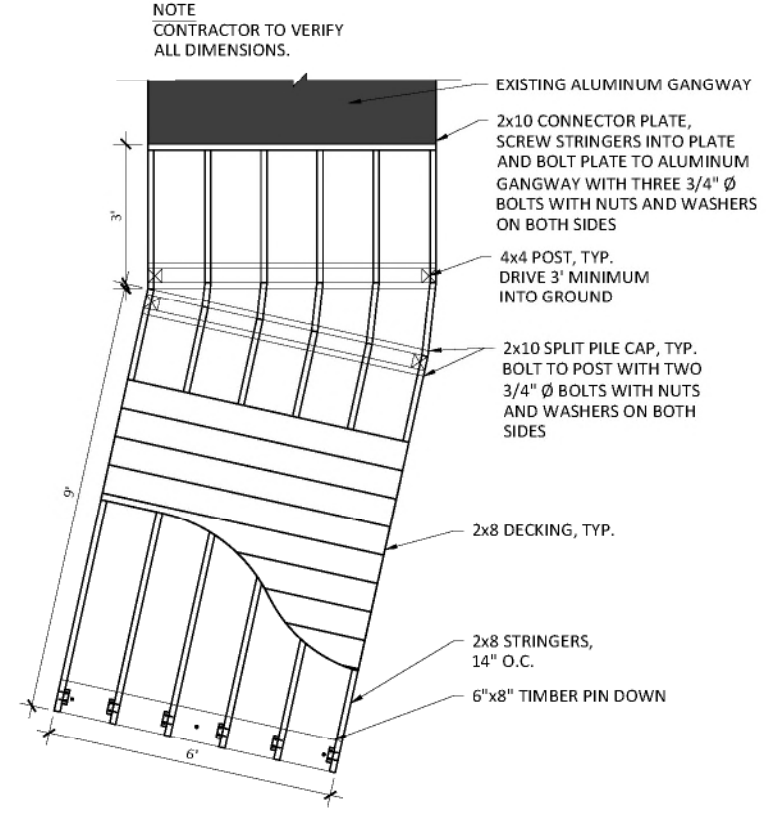

2 WEST SIDE GANGWAY APPROACH - FRAMING PLAN
1/2" = 1'-0"

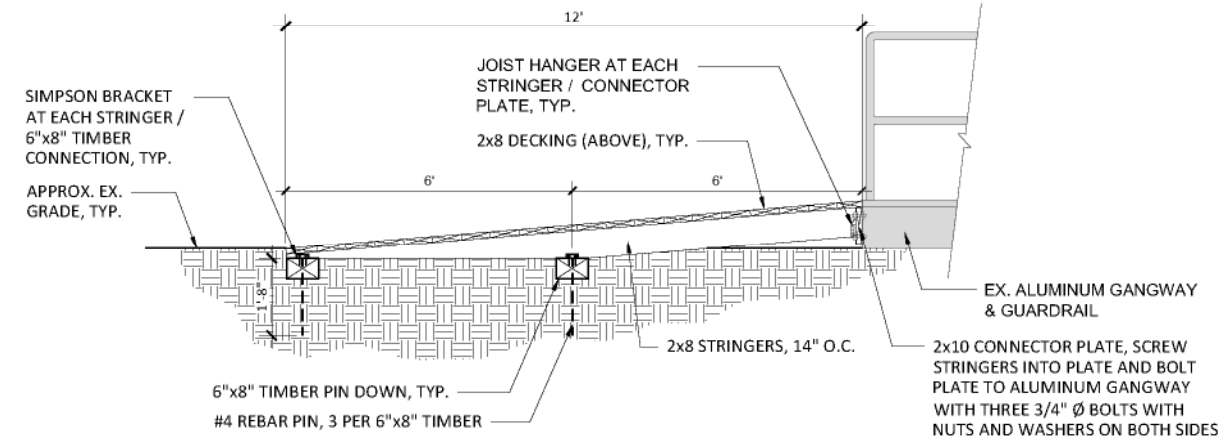

3 EAST SIDE GANGWAY APPROACH - SECTION
1/2" = 1'-0"

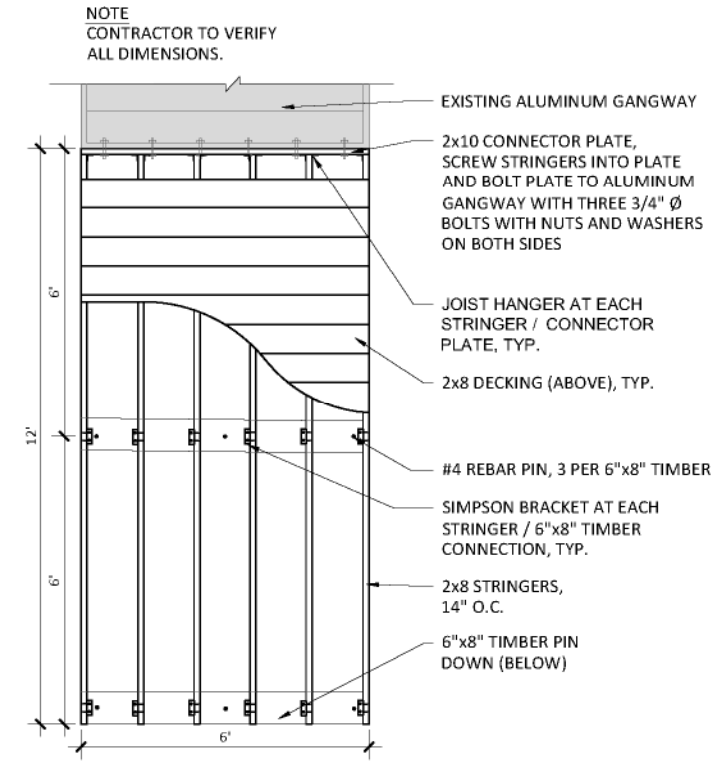

4 EAST SIDE GANGWAY APPROACH - FRAMING PLAN
1/2" = 1'-0"

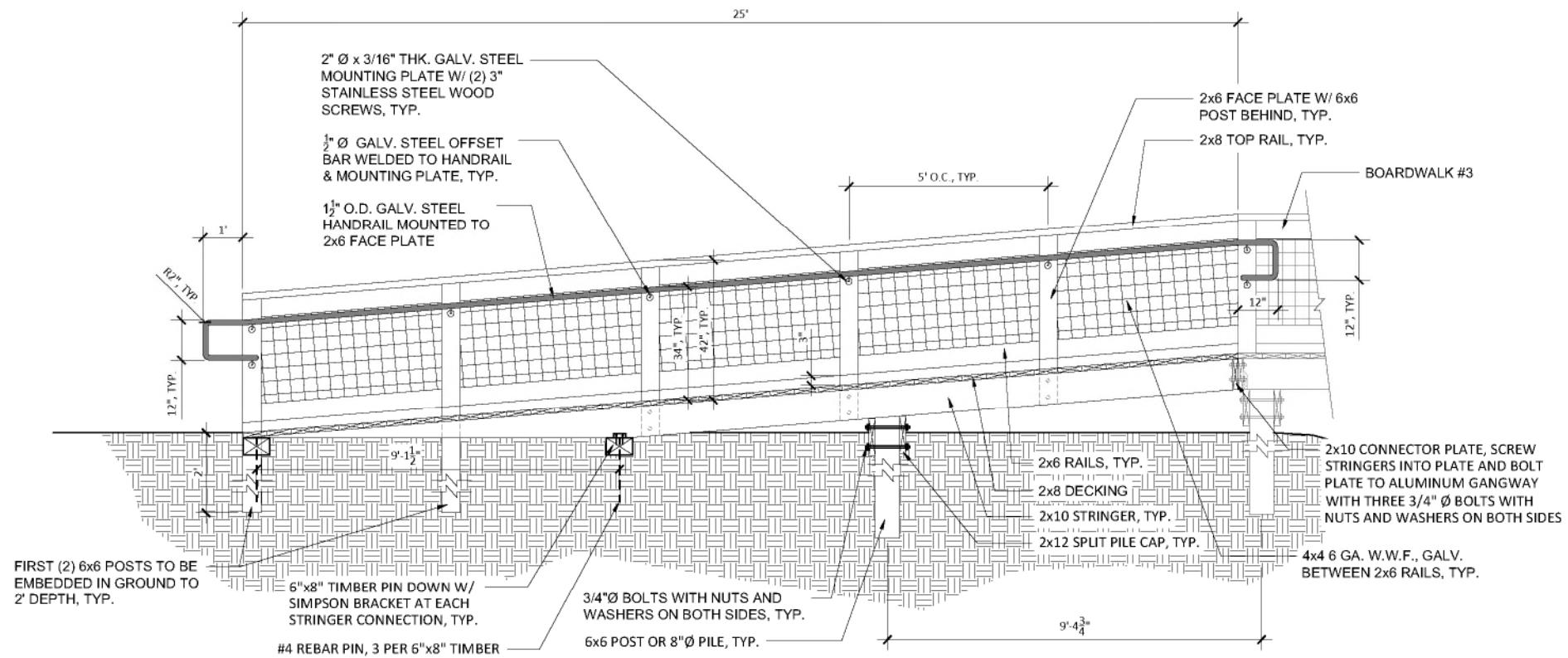

1 RAMP @ BEGINNING OF BOARDWALK #3 - LONGITUDINAL SECTION
1/2" = 1'-0"

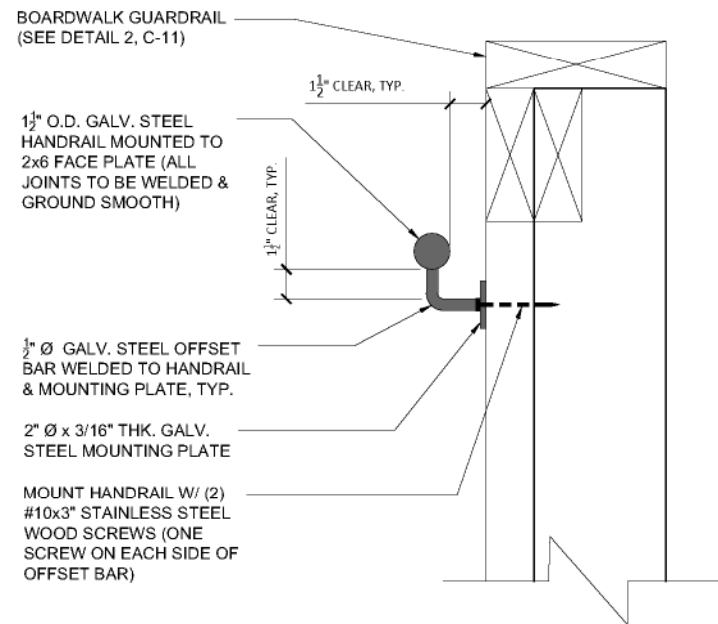

2 GALV. STEEL HANDRAIL - CROSS SECTION
3" = 1'-0"

Revisions:

NO.	DATE	DESCRIPTION
1	11/20/2023	UPDATED TOPO

REFER TO STRUCTURAL PLANS FOR MEMBER SIZES, CONNECTIONS, FASTENERS, AND FOUNDATIONS.

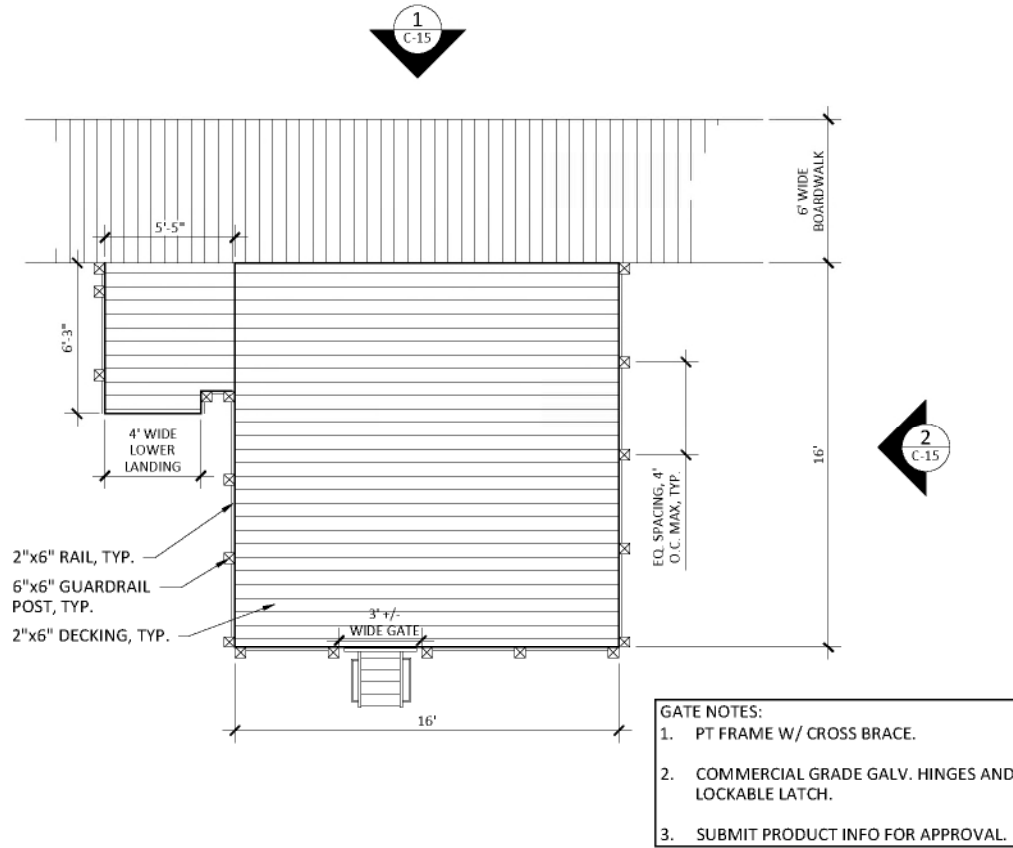

- GATE NOTES:**
1. PT FRAME W/ CROSS BRACE.
 2. COMMERCIAL GRADE GALV. HINGES AND LOCKABLE LATCH.
 3. SUBMIT PRODUCT INFO FOR APPROVAL.

1 PLATFORM FLOOR PLAN - LOWER PLATFORM
1/4" = 1'-0"

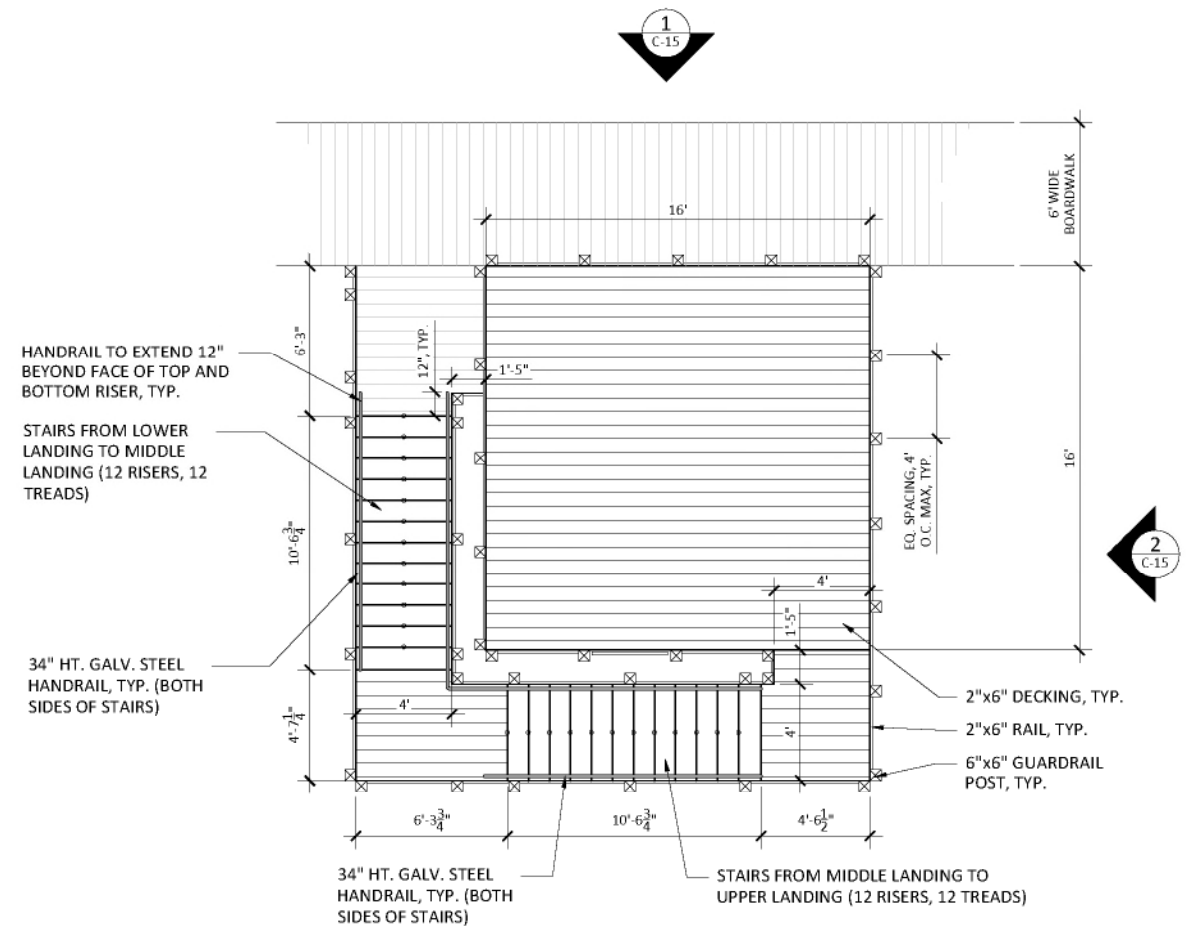

2 PLATFORM FLOOR PLAN - UPPER PLATFORM
1/4" = 1'-0"

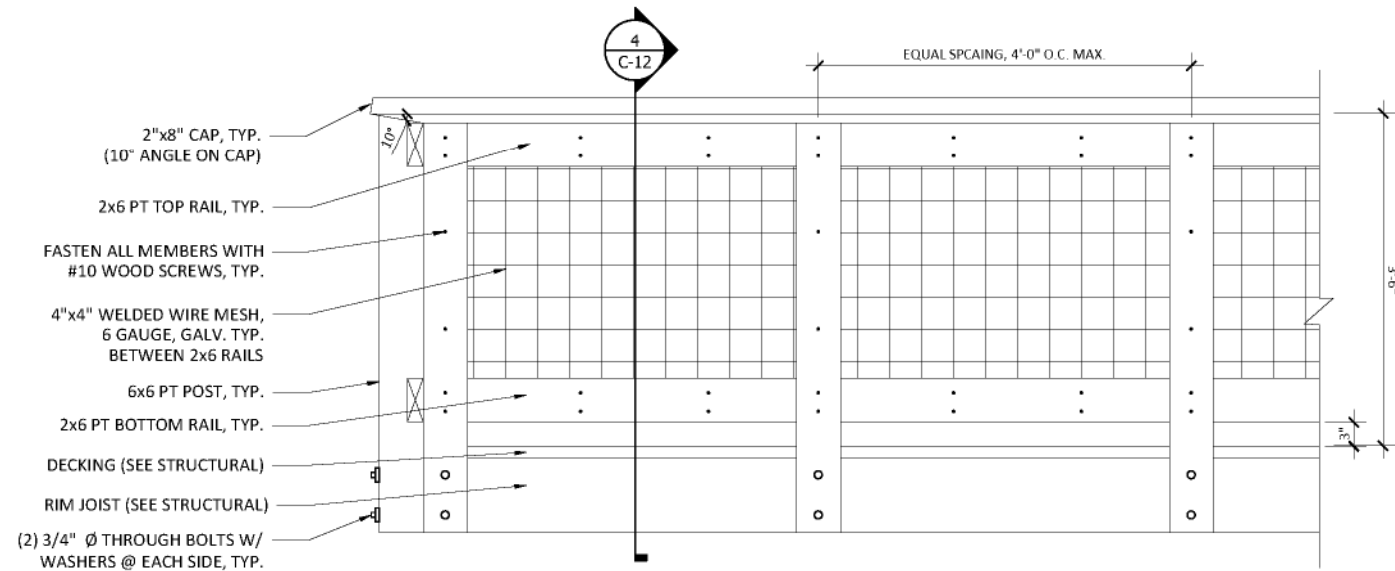

3 42" GUARDRAIL - TYPICAL ELEVATION
1" = 1'-0"

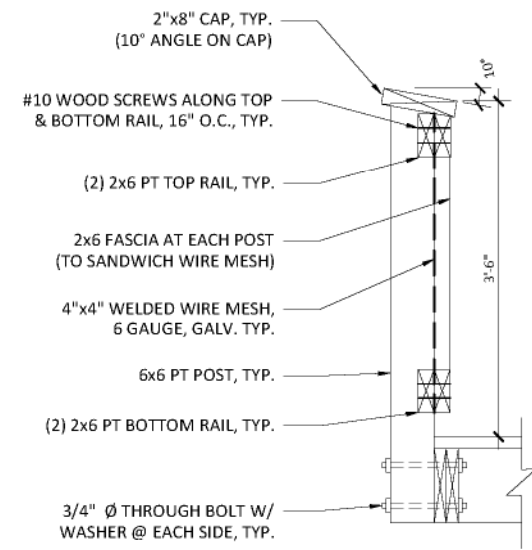

4 42" GUARDRAIL - TYPICAL SECTION
1" = 1'-0"

FREEDMAN ENGINEERING GROUP
David Freedman, PE, LEED AP-BD&C
1000 Whitlock Avenue
Suite 320, #218
Marietta, GA 30064
(770) 851-3175
David@Freedmanengineering.com



Date: 05/16/2023
Project No:
Drawn By: MW
Checked By: DF

DEAN CREEK NATURE TRAIL IMPROVEMENTS
GEORGIA DEPARTMENT OF NATURAL RESOURCES
#2 MARTIN LUTHER KING, JR. DRIVE, SUITE 1352
ATLANTA, GA 30334

Revisions:

NO.	DATE	DESCRIPTION
1	11/20/2023	UPDATED TOPO

Sheet Title:
CONSTRUCTION DETAILS

Sheet No:
C-12

RELEASED FOR CONSTRUCTION

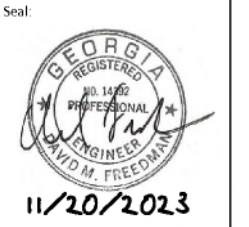

Date: 05/16/2023
Project No:
Drawn By: MW
Checked By: DF

REFER TO STRUCTURAL PLANS FOR
MEMBER SIZES, CONNECTIONS,
FASTENERS, AND FOUNDATIONS.

- LADDER TO MARSH NOTES:**
- MANUFACTURER**
THE DOCK DOCTORS, LLC
(800) 870-6756
thedockdoctors.com
 - SHALLOW WATER STAIRS**
MODEL: ONE-PIECE WELDED
ALUMINUM SHALLOW WATER DOCK
STAIRS WITH ALUMINUM
HANDRAILS, NON-SLIP TREADS &
ADJUSTABLE FOOTPADS
 - SIZE**
NUMBER OF TREADS TO BE
DETERMINED BY FIELD CONDITIONS.
 - ATTACHMENT**
SEE STRUCTURAL

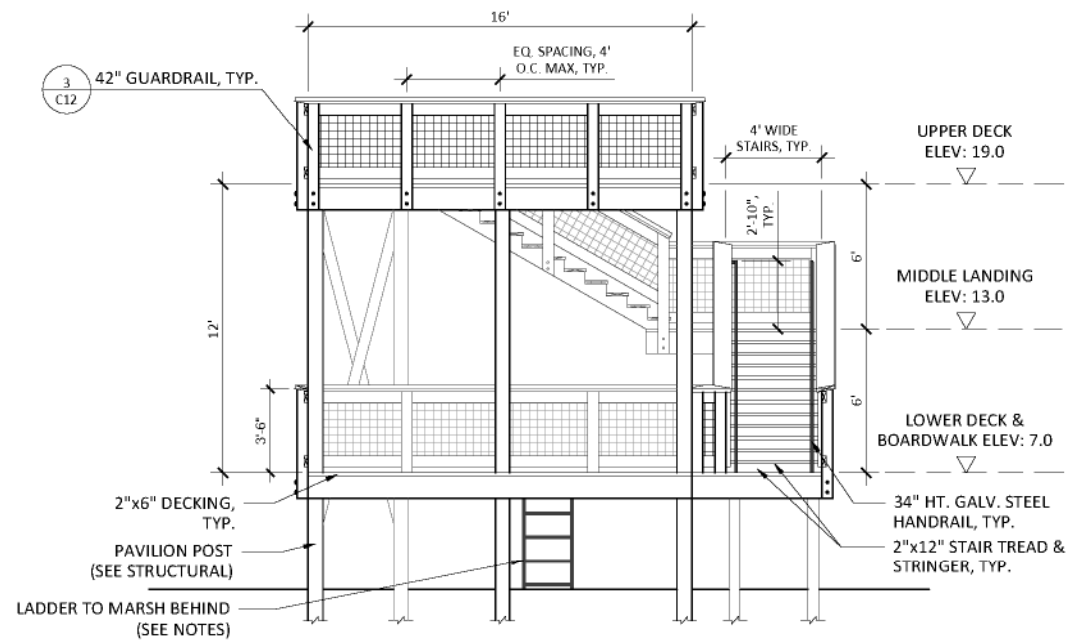

1 PLATFORM FRONT ELEVATION
1/4" = 1'-0"

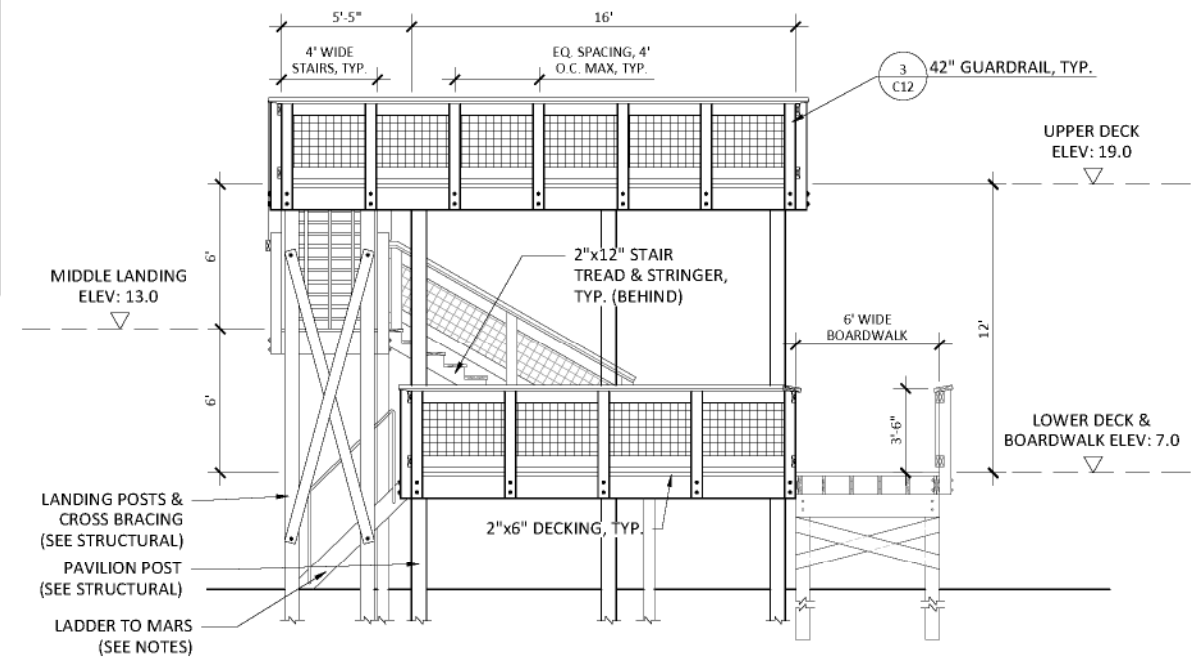

2 PLATFORM LEFT SIDE ELEVATION
1/4" = 1'-0"

**DEAN CREEK
NATURE TRAIL IMPROVEMENTS**

GEORGIA DEPARTMENT OF NATURAL RESOURCES
#2 MARTIN LUTHER KING, JR. DRIVE, SUITE 1352
ATLANTA, GA 30334

Revisions:

NO.	DATE	DESCRIPTION
1	11/20/2023	UPDATED TOPO

Sheet Title:
**CONSTRUCTION
DETAILS**

Sheet No:
C-13

SOILS NOTE:
ALL SOILS WITHIN THE PROJECT AREA ARE DUNE LAND, DsL.

- EROSION CONTROL PLAN NOTES:**
1. CONSTRUCTION ACCESS PATH TO BE 14 FEET WIDE, 7 FEET ON EITHER SIDE OF THE BOARDWALK CENTERLINE. MATS TO BE PLACED ON THE GROUND IN ALL AREAS WITHIN THE DNR JURISDICTIONAL LINE.
 2. HIGH TIDE LINE ELEVATION = 5.32.
 3. MEANT HIGH WATER ELEVATION = 2.9.

FREEDMAN ENGINEERING GROUP

David Freedman, PE, LEED AP-BD&C
1000 Whitlock Avenue
Suite 320, #218
Marietta, GA 30064
(770) 851-3175
David@Freedmanengineering.com

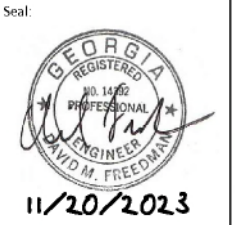

Date: 05/16/2023
Project No:
Drawn By: MW
Checked By: DF

**DEAN CREEK
NATURE TRAIL IMPROVEMENTS**

GEORGIA DEPARTMENT OF NATURAL RESOURCES
#2 MARTIN LUTHER KING, JR. DRIVE, SUITE 1352
ATLANTA, GA 30334

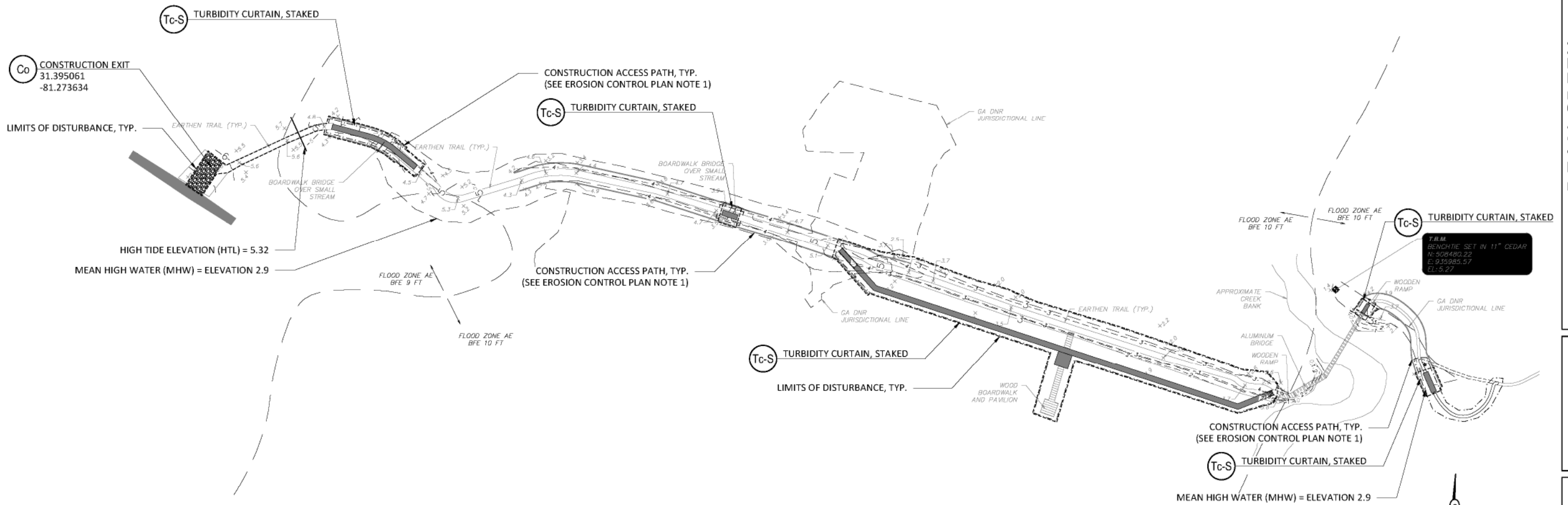

Revisions:

NO.	DATE	DESCRIPTION
1	11/20/2023	UPDATED TOPO

Sheet Title:
EROSION AND SEDIMENTATION CONTROL PLAN

Sheet No:
C-14

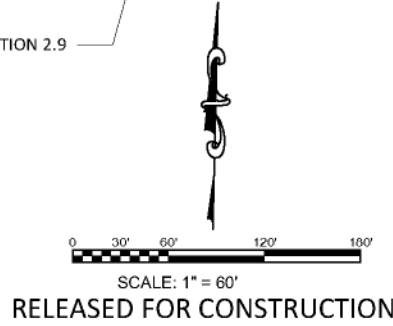

EROSION, SEDIMENTATION & POLLUTION CONTROL PLAN CHECKLIST
STAND ALONE CONSTRUCTION PROJECTS

SWCD: W Coastal Region 3

Project Name: Dean Creek Nature Trail Improvements Address: Sapelo Island, GA, 31037

City/County: Sapelo Island/McIntosh Date on Plans: 5/16/2023

Name & email of person filling out checklist: David Freedman, David@Freedmanengineering.com

Plan included **TO BE SHOWN ON ES&PC PLAN**

- | Page # | Y/N | |
|--------|-----|--|
| C-15 | Y | 1 The applicable Erosion, Sedimentation and Pollution Control Plan Checklist established by the Commission as of January 1 of the year in which the land-disturbing activity was permitted.
(The completed Checklist must be submitted with the ES&PC Plan or the Plan will not be reviewed) |
| C-1 | Y | 2 Level II certification number issued by the Commission, signature and seal of the certified design professional. (Signature, seal and level II number must be on each sheet pertaining to ES&PC plan or the Plan will not be reviewed) |
| N/A | N/A | 3 Limits of disturbance shall be no greater than 50 acres at any one time without prior written authorization from the GAEPD District Office. If GAEPD approves the request to disturb 50 acres or more at any one time, the Plan must include at least 4 of the BMPs listed in Appendix 1 of this checklist and the GAEPD approval letter. *
(A copy of the written approval by GAEPD must be attached to the plan for the Plan to be reviewed.) |
| C-1 | Y | 4 The name and phone number of the 24-hour contact responsible for erosion, sedimentation and pollution controls. |
| C-16 | Y | 5 Provide the name, address, email address, and phone number of primary permittee. |
| C-16 | Y | 6 Note total and disturbed acreages of the project or phase under construction. |
| C-14 | Y | 7 Provide the GPS location of the construction exit for the site. Give the Latitude and Longitude in decimal degrees. |
| C-16 | Y | 8 Initial date of the Plan and the dates of any revisions made to the Plan including the entity who requested the revisions. |
| C-16 | Y | 9 Description of the nature of construction activity and existing site conditions. |
| C-1 | Y | 10 Provide vicinity map showing site's relation to surrounding areas. Include designation of specific phases, if necessary. |
| C-16 | Y | 11 Identify the project receiving waters and describe all sensitive adjacent areas including streams, lakes, residential areas, wetlands, marshlands, etc. which may be affected. |
| C-16 | Y | 12 Design professional's certification statement and signature that the site was visited prior to development of the ES&PC Plan as stated on Part IV page 19 of the permit. |
| N/A | N/A | 13 Design professional's certification statement and signature that the permittee's ES&PC Plan provides for an appropriate and comprehensive system of BMPs and sampling to meet permit requirements as stated on Part IV page 19 of the permit. * |
| N/A | N/A | 14 Clearly note the statement that "The design professional who prepared the ES&PC Plan is to inspect the installation of the initial sediment storage requirements and perimeter control BMPs within 7 days after installation." in accordance with Part IV.A.5 page 25 of the permit. * |
| C-16 | Y | 15 Clearly note the statement that "Non-exempt activities shall not be conducted within the 25 or 50-foot undisturbed stream buffers as measured from the point of westerly vegetation or within 25-feet of the coastal marshland buffer as measured from the Jurisdictional Determination Line without first acquiring the necessary variances and permits." |
| C-16 | Y | 16 Provide a description of any buffer encroachments and indicate whether a buffer variance is required. |
| N/A | N/A | 17 Clearly note the statement that "Amendments/revisions to the ES&PC Plan which have a significant effect on BMPs with a hydraulic component must be certified by the design professional." * |

- | | | |
|------|-----|---|
| N/A | N/A | 18 Clearly note the statement that "Waste materials shall not be discharged to waters of the State, except as authorized by a Section 404 permit." * |
| C-16 | Y | 19 Clearly note statement that "The escape of sediment from the site shall be prevented by the installation of erosion and sediment control measures and practices prior to land disturbing activities." |
| C-16 | Y | 20 Clearly note statement that "Erosion control measures will be maintained at all times. If full implementation of the approved Plan does not provide for effective erosion control, additional erosion and sediment control measures shall be implemented to control or treat the sediment source." |
| C-16 | Y | 21 Clearly note the statement "Any disturbed area left exposed for a period greater than 14 days shall be stabilized with mulch or temporary seeding." |
| N/A | N/A | 22 Any construction activity which discharges storm water into an Impaired Stream Segment, or within 1 linear mile upstream of and within the same watershed as, any portion of a Biota Impaired Stream Segment must comply with Part III.C. of the permit. Include the completed Appendix 1 listing all the BMPs that will be used for those areas of the site which discharge to the Impaired Stream Segment. * |
| N/A | N/A | 23 If a TMDL Implementation Plan for sediment has been finalized for the Impaired Stream Segment (identified in Item 22 above) at least six months prior to submittal of NOI, the ES&PC Plan must address any site-specific conditions or requirements included in the TMDL Implementation Plan. * |
| N/A | N/A | 24 BMPs for concrete washdown of tools, concrete mixer chutes, hoppers and the rear of the vehicles. Washout of the drum at the construction site is prohibited. * |
| C-16 | Y | 25 Provide BMPs for the remediation of all petroleum spills and leaks. |
| N/A | N/A | 26 Description of the measures that will be installed during the construction process to control pollutants in storm water that will occur after construction operations have been completed. * |
| N/A | N/A | 27 Description of practices to provide cover for building materials and building products on site. * |
| N/A | N/A | 28 Description of the practices that will be used to reduce the pollutants in storm water discharges. * |
| C-16 | Y | 29 Description and chart or timeline of the intended sequence of major activities which disturb soils for the major portions of the site (i.e., initial perimeter and sediment storage BMPs, clearing and grubbing activities, excavation activities, utility activities, temporary and final stabilization). |
| N/A | N/A | 30 Provide complete requirements of inspections and record keeping by the primary permittee. * |
| N/A | N/A | 31 Provide complete requirements of Sampling Frequency and Reporting of sampling results. * |
| N/A | N/A | 32 Provide complete details for Retention of Records as per Part IV.F. of the permit. * |
| N/A | N/A | 33 Description of analytical methods to be used to collect and analyze the samples from each location. * |
| N/A | N/A | 34 Appendix B rationale for NTU values at all outfall sampling points where applicable. * |
| N/A | N/A | 35 Delineate all sampling locations, perennial and intermittent streams and other water bodies into which storm water is discharged. * |
| N/A | N/A | 36 A description of appropriate controls and measures that will be implemented at the construction site including:
(1) initial sediment storage requirements and perimeter control BMPs, (2) intermediate grading and drainage BMPs, and (3) final BMPs. For construction sites where there will be no mass grading and the initial perimeter control BMPs, intermediate grading and drainage BMPs, and final BMPs are the same, the Plan may combine all of the BMPs into a single phase. * |

- | C-14 | Y | 37 Graphic scale and North arrow. | | | | | | |
|--------------------------------|---|---|-----------|--------------|-----------------------|--------------------------------|---|---------------------------------|
| C-14 | Y | 38 Existing and proposed contour lines with contour lines drawn at an interval in accordance with the following:
<table border="1"> <tr> <th>Map Scale</th> <th>Ground Slope</th> <th>Contour Interval, ft.</th> </tr> <tr> <td>1 inch = 100ft or larger scale</td> <td>Flat 0 - 2%
Rolling 2 - 6%
Steep 6% +</td> <td>0.5 or 1
1 or 2
2.5 or 10</td> </tr> </table> | Map Scale | Ground Slope | Contour Interval, ft. | 1 inch = 100ft or larger scale | Flat 0 - 2%
Rolling 2 - 6%
Steep 6% + | 0.5 or 1
1 or 2
2.5 or 10 |
| Map Scale | Ground Slope | Contour Interval, ft. | | | | | | |
| 1 inch = 100ft or larger scale | Flat 0 - 2%
Rolling 2 - 6%
Steep 6% + | 0.5 or 1
1 or 2
2.5 or 10 | | | | | | |
| C-16 | Y | 39 Use of alternative BMPs whose performance has been documented to be equivalent to or superior to conventional BMPs as certified by a Design Professional (unless disapproved by GAEPD or the Georgia Soil and Water Conservation Commission). Please refer to the Alternative BMP Guidance Document found at www.gsewcc.georgia.gov. | | | | | | |
| N/A | N/A | 40 Use of alternative BMP for application to the Equivalent BMP List. Please refer to Appendix A-2 of the Manual for Erosion & Sediment Control in Georgia 2016 Edition. * | | | | | | |
| C-14 | Y | 41 Delineation of the applicable 25-foot or 50-foot undisturbed buffers adjacent to state waters and any additional buffers required by the Local Issuing Authority. Clearly note and delineate all areas of impact. | | | | | | |
| C-14 | Y | 42 Delineation of on-site wetlands and all state waters located on and within 200 feet of the project site. | | | | | | |
| C-16 | Y | 43 Delineation and acreage of contributing drainage basins on the project site. | | | | | | |
| N/A | N/A | 44 Provide hydrology study and maps of drainage basins for both the pre- and post-developed conditions. * | | | | | | |
| C-16 | Y | 45 An estimate of the runoff coefficient or peak discharge flow of the site prior to and after construction activities are completed. | | | | | | |
| C-16 | Y | 46 Storm-drain pipe and weir velocities with appropriate outlet protection to accommodate discharges without erosion. Identify/Delineate all storm water discharge points. | | | | | | |
| C-14 | Y | 47 Soil series for the project site and their delineation. | | | | | | |
| C-16 | Y | 48 The limits of disturbance for each phase of construction. | | | | | | |
| C-16 | Y | 49 Provide a minimum of 67 cubic yards of sediment storage per acre drained using a temporary sediment basin, retrofitted detention pond, and/or excavated inlet sediment traps for each common drainage location. Sediment storage volume must be in place prior to and during all land disturbance activities until final stabilization of the site has been achieved. A written justification explaining the decision to use equivalent controls when a sediment basin is not attainable must be included in the Plan for each common drainage location in which a sediment basin is not provided. A written justification as to why 67 cubic yards of storage is not attainable must also be given. Worksheets from the Manual included for structural BMPs and all calculations used by the design professional to obtain the required sediment when using equivalent controls. When discharging from sediment basins and impoundments, permittees are required to utilize outlet structures that withdraw water from the surface, unless infeasible. If outlet structures that withdraw water from the surface are not feasible, a written justification explaining this decision must be included in the Plan. | | | | | | |
| C-14 | Y | 50 Location of Best Management Practices that are consistent with and no less stringent than the Manual for Erosion and Sediment Control in Georgia. Use uniform coding symbols from the Manual, Chapter 6, with legend. | | | | | | |
| C-15 | Y | 51 Provide detailed drawings for all structural practices. Specifications must, at a minimum, meet the guidelines set forth in the Manual for Erosion and Sediment Control in Georgia. | | | | | | |
| C-16 | Y | 52 Provide vegetative plan, noting all temporary and permanent vegetative practices. Include species, planting dates and seeding, fertilizer, lime and mulching rates. Vegetative plan shall be site specific for appropriate time of the year that seeding will take place and for the appropriate geographic region of Georgia.
* If using this checklist for a project that is less than 1 acre and not part of a common development but within 200 ft of a perennial stream, the * checklist items would be N/A. | | | | | | |

Effective January 1, 2023

FREEDMAN ENGINEERING GROUP

David Freedman, PE, LEED AP-BD&C
 1000 Whitlock Avenue
 Suite 320, #218
 Marietta, GA 30064
 (770) 851-3175
 David@Freedmanengineering.com

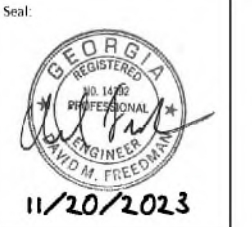

Date: 05/16/2023
 Project No:
 Drawn By: MW
 Checked By: DF

DEAN CREEK NATURE TRAIL IMPROVEMENTS
 GEORGIA DEPARTMENT OF NATURAL RESOURCES
 #2 MARTIN LUTHER KING, JR. DRIVE, SUITE 1352
 ATLANTA, GA 30334

Revisions:

NO.	DATE	DESCRIPTION
1	11/20/2023	UPDATED TOPO

Sheet Title:
EROSION AND SEDIMENTATION CONTROL DETAILS AND NOTES

Sheet No:
C-15

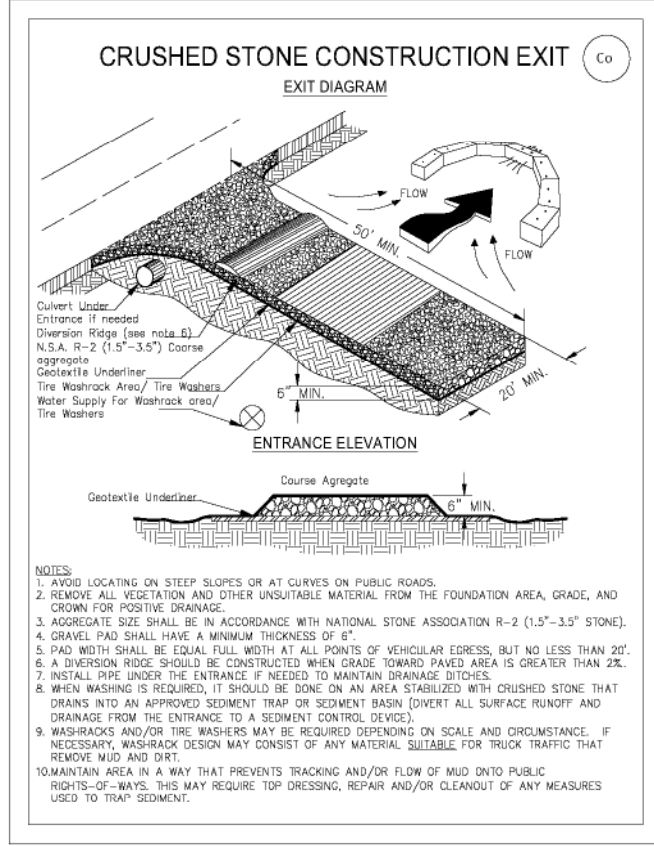
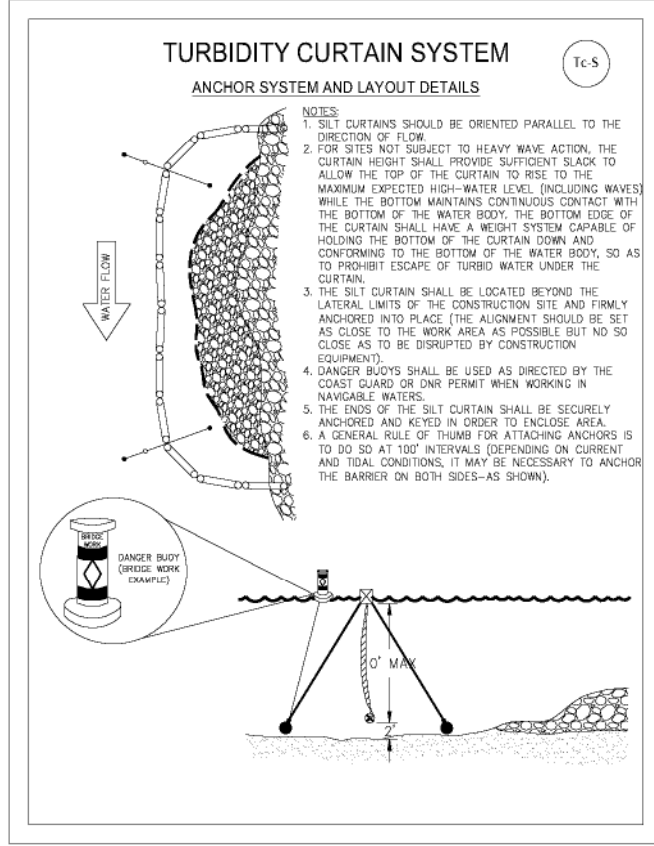

NOTE:
 CONSTRUCTION EXIT AS NEEDED
 BASED ON SITE CONDITIONS.

FREEDMAN ENGINEERING GROUP

David Freedman, PE, LEED AP-BD&C
 1000 Whitlock Avenue
 Suite 320, #218
 Marietta, GA 30064
 (770) 851-3175
 David1@Freedmanengineering.com

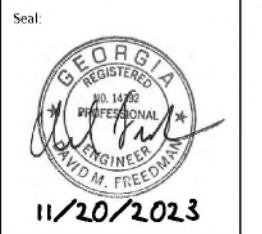

Date: 05/16/2023
 Project No:
 Drawn By: MW
 Checked By: DF

DEAN CREEK NATURE TRAIL IMPROVEMENTS

GEORGIA DEPARTMENT OF NATURAL RESOURCES
 #2 MARTIN LUTHER KING, JR. DRIVE, SUITE 1352
 ATLANTA, GA 30334

Revisions:

NO.	DATE	DESCRIPTION
1	11/20/2023	UPDATED TOPO

Sheet Title:
EROSION AND SEDIMENTATION CONTROL DETAILS AND NOTES

Sheet No:
C-16

PROJECT DESCRIPTION

THE PROJECT CONSISTS OF REPLACING AN EXISTING BOARDWALK, CONSTRUCTING A NEW BOARDWALK AND OBSERVATION PLATFORM, AND REMOVING AN EXISTING EARTHEN CAUSEWAY. THE DISTURBED AREA IS 0.72 ACRE AND THE VOLUME OF EARTH TO BE DISTURBED IS 517 CUBIC YARDS.

CONSTRUCTION ACTIVITIES FOR THE PROJECT WILL INCLUDE THE FOLLOWING:

- INSTALLATION AND MAINTENANCE OF EROSION AND SEDIMENTATION CONTROL MEASURES
- DEMOLITION
- CONSTRUCTION
- ESTABLISHING TEMPORARY AND PERMANENT VEGETATION

DISTURBED AREAS WILL BE RESTORED WITH PERMANENT GRASS VEGETATION AND LANDSCAPE MULCHING. THE REMAINING AREAS DISTURBED BY CONSTRUCTION ACTIVITIES WILL BE RETURNED TO THEIR ORIGINAL CONDITIONS. TOPOGRAPHY WILL BE RETURNED TO ORIGINAL GRADE AND SLOPE AS MUCH AS POSSIBLE, AND RUNOFF COEFFICIENTS WILL BE COMPARABLE TO PRE CONSTRUCTION VALUES. STORM WATER RUNOFF RATES WILL BE MINIMALLY AFFECTED AS A RESULT OF THIS PROJECT.

STORM-DRAIN PIPE AND WEIR VELOCITIES:

EXISTING SITE DRAINAGE PATTERNS WILL NOT BE ALTERED AS A RESULT OF THE PROJECT. NO STORM DRAINAGE STRUCTURES WILL BE INSTALLED.

SEDIMENT STORAGE:

CONSTRUCTION ACTIVITY IS LIMITED TO INSTALLING AND MAINTAINING EROSION CONTROL MEASURES AND SITE IMPROVEMENTS. GIVEN THE SMALL SITE DRAINAGE AREA ASSOCIATED WITH THIS PROJECT AS WELL AS THE LINEAR NATURE OF THE IMPROVEMENTS, DIVERTING FLOWS AND/OR CONSTRUCTING TEMPORARY SEDIMENT BASINS OR EQUIVALENT CONTROLS IS NOT FEASIBLE. SILT FENCE, MULCHING, AND GRASSING WILL BE USED FOR SEDIMENT CONTROL FOR THE PROJECT.

DISTURBED AREA TOTAL = 0.72 ACRE

REQUIRED VOLUME OF SEDIMENT STORAGE = (0.06 ACRES)(67 C.Y./ACRE) = 4.02 CUBIC YARDS

SILT FENCE STORAGE = 1 L.F. X 1.5' HIGH X 1.5' DEEP = 0.003 C.Y./L.F.

TOTAL AMOUNT OF SILT FENCE REQUIRED FOR SEDIMENT STORAGE = (4.02 CUBIC YARDS)/(0.003 CUBIC YARDS/LINEAR FOOT) = 561 LINEAR FEET

THE AMOUNT OF SILT FENCE SHOWN ON THE PLANS EXCEEDS THIS AMOUNT.

SEDIMENT ACCUMULATED BEHIND SILT FENCE WILL BE REMOVED WITHIN 3 DAYS OF A STORM EVENT.

POLLUTION PREVENTION PRACTICES & REMEDIATION OF PETROLEUM SPILLS AND LEAKS:

THE CONTRACTOR IS PROHIBITED FROM STORING OIL OR ANY HAZARDOUS WASTE MATERIAL AT THE CONSTRUCTION SITE. CONSTRUCTION EQUIPMENT AND VEHICLES ARE THE ONLY ANTICIPATED SOURCE OF POTENTIAL POLLUTION EXPECTED WITHIN THE CONSTRUCTION AREA FOR THIS PROJECT.

PREVENTION OF SPILLS AND LEAKS:

THE CONTRACTOR IS RESPONSIBLE FOR MINIMIZING THE POTENTIAL OF POLLUTION FROM EQUIPMENT AND VEHICLE LEAKS OR SPILLS REACHING ANY RECEIVING WATERS. AT A MINIMUM, THE FOLLOWING PRACTICES SHALL BE IMPLEMENTED:

REGULARLY INSPECT ON-SITE VEHICLES AND EQUIPMENT FOR LEAKS AND REPAIR IMMEDIATELY.

CHECK INCOMING VEHICLES AND EQUIPMENT FOR LEAKING OIL AND FLUIDS. DO NOT ALLOW LEAKING VEHICLES OR EQUIPMENT ON-SITE.

IF FUELING MUST OCCUR ON-SITE, USE LOCATIONS AWAY FROM DRAINAGE COURSES TO PREVENT THE RUNOFF OF STORMWATER AND THE RUNOFF OF SPILLS. ALWAYS USE SECONDARY CONTAINMENT, SUCH AS A DRAIN PAN, WHEN FUELING TO CATCH SPILLS/LEAKS.

IF MAINTENANCE MUST OCCUR ON-SITE, USE A DESIGNATED AREA AND SECONDARY CONTAINMENT, LOCATED AWAY FROM DRAINAGE COURSES, TO PREVENT THE RUNOFF OF STORMWATER AND THE RUNOFF OF SPILLS.

ALWAYS USE SECONDARY CONTAINMENT, SUCH AS DRAIN PAN OR DROP CLOTH, TO CATCH SPILLS OR LEAKS WHEN REMOVING OR CHANGING FLUIDS. PROMPTLY TRANSFER USED FLUIDS TO PROPER WASTE OR RECYCLING CONTAINERS. IMMEDIATELY REMOVE FROM SITE AND DISPOSE OF IN ACCORDANCE WITH LOCAL, STATE AND FEDERAL REGULATIONS.

TO THE EXTENT THAT THE WORK CAN BE ACCOMPLISHED SAFELY, SPILLS OF OIL OR PETROLEUM PRODUCTS SHOULD BE CONTAINED AND CLEANED UP IMMEDIATELY. SPILLS SHOULD BE COVERED AND PROTECTED FROM STORMWATER RUNOFF DURING RAINFALL TO THE EXTENT THAT IT DOESN'T COMPROMISE CLEAN UP ACTIVITIES.

CLEANUP OF PETROLEUM LEAKS OR SPILLS:

CLEAN UP LEAKS AND SPILLS IMMEDIATELY. NEVER HOSE DOWN OR BURY SPILLS. REMOVE CONTAMINATED SOILS AND DISPOSE OF IN ACCORDANCE WITH LOCAL, STATE AND FEDERAL REGULATIONS.

MINOR SPILLS

CONTAIN THE SPREAD OF THE SPILL, REMOVE CONTAMINATED SOILS, AND DISPOSE OF IN ACCORDANCE WITH LOCAL, STATE AND FEDERAL REGULATIONS.

SEMI-SIGNIFICANT SPILLS

SPILLS SHOULD BE CLEANED UP IMMEDIATELY WITH THE AID OF AS MANY ON-SITE PERSONNEL AS NECESSARY. IMMEDIATELY CONTAIN THE SPILL BY CONSTRUCTING AN EARTHEN DIKE. DIG UP AND PROPERLY DISPOSE OF CONTAMINATED SOIL IN ACCORDANCE WITH LOCAL, STATE AND FEDERAL REGULATIONS.

SIGNIFICANT SPILLS

FOR SIGNIFICANT SPILLS THAT CANNOT BE CONTROLLED BY PERSONNEL IN THE IMMEDIATE VICINITY, THE FOLLOWING STEPS SHOULD BE TAKEN:

NOTIFY THE LOCAL EMERGENCY RESPONSE BY CONTACTING 911. IN ADDITION TO 911, THE CONTRACTOR WILL NOTIFY THE PROPER 24 HOUR EMERGENCY CONTACT. THE SERVICES OF A SPILLS CONTRACTOR OR A HAZ-MAT TEAM SHOULD BE OBTAINED IMMEDIATELY. CONSTRUCTION PERSONNEL SHOULD NOT ATTEMPT TO CLEAN UP UNTIL THE APPROPRIATE AND QUALIFIED STAFFS HAVE ARRIVED AT THE JOB SITE.

THE CONTRACTOR IS REQUIRED TO ADHERE TO ALL REPORTING REQUIREMENTS OF GEORGIA'S OIL OR HAZARDOUS MATERIAL SPILLS OR RELEASES ACT (O.C.G.A. §§12-14-2, ET SEQ.), 40 CFR PART 117 AND 40 CFR PART 302 WHERE A RELEASE CONTAINING A HAZARDOUS SUBSTANCE IN AN AMOUNT EQUAL TO OR IN EXCESS OF A REPORTING QUANTITY ESTABLISHED UNDER EITHER GEORGIA'S OIL OR HAZARDOUS MATERIAL SPILLS OR RELEASES ACT (O.C.G.A. §§12-14-2, ET SEQ.), 40 CFR 117 OR 40 CFR 302 OCCURS DURING A 24 HOUR PERIOD. THE CONTRACTOR IS REQUIRED TO NOTIFY EPA AT (804) 658-4883 OR (800) 241-4113 AND THE NATIONAL RESPONSE CENTER (NRC) AT (800) 424-8802 IN ACCORDANCE WITH THE REQUIREMENTS OF GEORGIA'S OIL OR HAZARDOUS MATERIAL SPILLS OR RELEASES ACT (O.C.G.A. §§12-14-2, ET SEQ.), 40 CFR 117 AND 40 CFR 302 AS SOON AS HE/SHE HAS KNOWLEDGE OF THE DISCHARGE.

POST CONSTRUCTION POLLUTION CONTROL MEASURES:

DISTURBED AREAS WILL BE RETURNED TO PRE-CONSTRUCTION GRADES AND SLOPES AND PERMANENT GRASS VEGETATION WILL BE ESTABLISHED AS WORK PROGRESSES TO CONTROL POLLUTANTS IN STORM WATER THAT WILL OCCUR AFTER CONSTRUCTION OPERATIONS HAVE BEEN COMPLETED.

THE CONTRACTOR SHALL ENSURE SATISFACTORY GROWTH AND COVERAGE OF PERMANENT GRASS VEGETATION ON DISTURBED AREAS. GRASSED AREAS WILL BE CONSIDERED ACCEPTABLE WHEN PERMANENT GRASS VEGETATION HAS REACHED A POINT OF MATURITY. COVERAGE IS AT LEAST 95% OF THE TOTAL AREA WITH NO BARE SPOTS EXCEEDING ONE SQUARE FOOT, AND GROUND SURFACE IS FULLY STABILIZED AGAINST EROSION. SILT FENCE AND MULCH INSTALLED DURING INSTALLATION OF THE PIPELINE WILL BE KEPT IN PLACE AND MAINTAINED UNTIL PERMANENT VEGETATION HAS BEEN EFFECTIVELY ESTABLISHED AND CONTRACTOR HAS RECEIVED FINAL ACCEPTANCE BY THE OWNER.

WASTE MATERIALS:

WASTE MATERIALS SHALL NOT BE DISCHARGED TO WATERS OF THE STATE, EXCEPT BY A SECTION 404 PERMIT. ANY WASTE MATERIAL FROM CONSTRUCTION ACTIVITIES SHALL BE COLLECTED AND STORED IN A SECURE, LIDDED CONTAINER. AT THE END OF EACH WORK DAY WASTE MATERIAL SHALL BE REMOVED FROM THE CONSTRUCTION SITE AND DISPOSED OF PROPERLY.

IF EXISTING SANITARY FACILITIES ARE UNAVAILABLE, PORTABLE SANITARY FACILITIES SHALL BE PROVIDED. CONTRACTOR SHALL PAY THE COST FOR INSTALLATION, MAINTENANCE, AND REMOVAL OF TEMPORARY SANITARY FACILITIES. UNITS SHALL BE CLEANED AND SANITARY WASTE SHALL BE COLLECTED A MINIMUM OF ONE TIME PER WEEK BY A LICENSED PORTABLE FACILITY PROVIDER AND IN COMPLIANCE WITH LOCAL AND STATE REGULATIONS.

UNITS SHALL BE LOCATED AT SUCH PLACES AS APPROVED BY THE OWNER AND WHERE THE LIKELIHOOD OF THE UNIT CONTRIBUTING TO STORM WATER DISCHARGE IS NEGLIGIBLE.

THESE PLANS ARE IN COMPLIANCE WITH APPLICABLE STATE AND LOCAL WASTE DISPOSAL, SANITARY SEWER, AND SEPTIC SYSTEM REGULATIONS.

INSPECTION OF BMP'S:

CONTRACTOR IS TO NOTIFY ES AND PC DESIGN PROFESSIONAL WHEN CONSTRUCTION IS TO BEGIN. THE DESIGN PROFESSIONAL WHO PREPARED THE ES AND PC PLAN IS TO INSPECT THE INSTALLATION OF THE INITIAL SEDIMENT STORAGE REQUIREMENTS AND PERIMETER CONTROL BMP'S WITHIN 7 DAYS AFTER INSTALLATION IN ACCORDANCE WITH PART IV A.5, PAGE 25 OF THE GENERAL NOTES PERMIT.

ES&PC PLAN AMENDMENTS/REVISIONS:

ANY AMENDMENT TO THE EROSION CONTROL PLANS WHICH HAS A SIGNIFICANT EFFECT ON BMP'S WITH A HYDRAULIC COMPONENT MUST BE CERTIFIED BY THE ES&PC PLAN DESIGN PROFESSIONAL.

CONCRETE WASHDOWN:

CONCRETE WASHDOWN OF TOOLS, CONCRETE MIXER CHUTES, HOPPERS, DRUMS, THE REAR OF VEHICLES, AND/OR ANY OTHER EQUIPMENT IS PROHIBITED ON THE PROJECT SITE.

PRIMARY PERMITTEE:

THE PRIMARY PERMITTEE FOR THIS SITE IS THE GEORGIA DEPARTMENT OF NATURAL RESOURCES, #2 MLK JR. DRIVE, SUITE 1352, ATLANTA, GA, 30334, 912-381-2511, JOEL.GREFF@DNR.GA.GOV.

STATE WATERS:

THIS PROJECT IS LOCATED WITHIN 200 FEET OF STATE WATERS. THERE IS A MINOR ENCROACHMENT ASSOCIATED WITH THIS PROJECT. THE RECEIVING WATERS FOR THIS PROJECT ARE DEAN CREEK. SINCE THE PROJECT HAS TO OBTAIN A CMAA PERMIT A BUFFER VARIANCE IS NOT REQUIRED.

EXISTING LAND USE:

THE EXISTING LANDS AT THE PROJECT SITE ARE A NATIONAL ESTUARINE RESEARCH RESERVE.

CRITICAL AREAS INFORMATION:

THERE ARE NO CRITICAL AREAS WITHIN THIS PROJECT.

WETLANDS:

THERE ARE WETLANDS WITHIN THE PROJECT AREA.

EROSION, SEDIMENTATION AND POLLUTION CONTROL INSPECTIONS AND REPORTING:

INSPECTIONS AND REPORTING REQUIREMENTS ARE NOT REQUIRED.

EROSION CONTROL NOTES:

EROSION CONTROL MEASURES WILL BE MAINTAINED AT ALL TIMES. IF FULL IMPLEMENTATION OF THE APPROVED PLAN DOES NOT PROVIDE FOR EFFECTIVE EROSION CONTROL, ADDITIONAL EROSION AND SEDIMENT CONTROL MEASURES SHALL BE IMPLEMENTED TO CONTROL OR TREAT THE SEDIMENT SOURCE.

ANY DISTURBED AREA LEFT EXPOSED FOR A PERIOD GREATER THAN 14 DAYS SHALL BE STABILIZED WITH MULCH OR TEMPORARY SEEDING.

THE ESCAPE OF SEDIMENT FROM THE SITE SHALL BE PREVENTED BY THE INSTALLATION OF EROSION AND SEDIMENT CONTROL MEASURES AND PRACTICES PRIOR TO, OR CONCURRENT WITH, LAND-DISTURBING ACTIVITIES.

THE EXTENT AND LOCATION OF EROSION CONTROL MEASURES SHOWN ARE THE ESTIMATED REQUIRED. ADDITIONAL EROSION CONTROL MEASURES MAY BE REQUIRED DUE TO THE ACTUAL FIELD CONDITIONS, AND WILL BE INSTALLED AT THE OWNER/DEVELOPERS EXPENSE WHEN DIRECTED BY THE PROPER GOVERNING AUTHORITY.

ALTERNATE TYPE C SILT FENCE CAN BE USED PROVIDED IT IS APPROVED BY THE GEORGIA DEPARTMENT OF TRANSPORTATION.

NO CLEARING OF THE SITE UNTIL ALL BASINS, DIVERSIONS, AND SEDIMENT CONTROLS ARE INSTALLED, STABILIZED, AND FUNCTIONAL.

THE GSWCC MANUAL REQUIRES TWO ROWS OF TYPE S SEDIMENT BARRIERS, 36 INCHES APART, ALONG ALL STATE WATERS.

IMPAIRED STREAM REQUIREMENTS, TMDL PLANS, AND ALTERNATIVE BMP NOTES

1. STORM WATER FROM THIS PROJECT WILL DISCHARGE INTO DEAN CREEK, A TIDAL STREAM THAT DISCHARGES INTO DOBOY SOUND, WHICH IS NOT AN IMPAIRED STREAM (SOUND/HARBOR).
2. ALTERNATIVE BMP'S WILL NOT BE INSTALLED DURING THIS PROJECT.

NON-EXEMPT ACTIVITIES SHALL NOT BE CONDUCTED WITHIN THE 25 OR 50 FOOT UNDISTURBED STREAM BUFFERS AS MEASURED FROM THE POINT OF WRESTED VEGETATION OR WITHIN 25 FEET OF A COASTAL MARSHLAND BUFFER AS MEASURED FROM THE JURISDICTIONAL DETERMINATION LINE WITHOUT FIRST ACQUIRING THE NECESSARY VARIANCES AND PERMITS.

GIVEN THE SMALL "SITE" DRAINAGE AREAS ASSOCIATED WITH THIS PROJECT, DIVERTING FLOWS AND/OR CONSTRUCTING TEMPORARY SEDIMENT BASINS OR EQUIVALENT CONTROLS IS NOT ATTAINABLE. SILT FENCE, TEMPORARY GRASSING, MULCHING AND PERMANENT GRASSING WILL BE USED FOR SEDIMENT CONTROL FOR THE PROJECT.

ACTIVITY	2020								
	MONTH								
	1	2	3	4	5	6	7	8	9
EROSION CONTROL INSTALLATION OF TURBIDITY CURTAIN (TC-S)	█								
DEMOLITION AND CONSTRUCTION									
MAINTAIN INSTALLED EROSION CONTROL BMP'S UNTIL PERMANENT VEGETATION IS ESTABLISHED AND EFFECTIVE CONTROL OF EROSION HAS BEEN ACHIEVED IN ALL AREAS DISTURBED BY CONSTRUCTION ACTIVITIES (TC-S)									

DRAINAGE BASIN INFORMATION

ONSITE DRAINAGE BASIN

AREA DESCRIPTION	RUNOFF COEFFICIENT (C)	PRE- CONSTRUCTION SIZE (SQUARE FEET)	PRE- CONSTRUCTION CA	POST- CONSTRUCTION SIZE (SQUARE FEET)	POST- CONSTRUCTION CA
WOODEN BOARDWALK	0.75	1,727	1,295	4,312	3,234
GRASS/VEGETATION	0.25	4,152	1,038	2,760	690
ALUMINUM GANGWAY	0.75	540	405	540	405
TOTAL		6,419	2,738	7,612	4,329

PRE-CONSTRUCTION RUNOFF COEFFICIENT = 2,738/6,419 = 0.43

POST-CONSTRUCTION RUNOFF COEFFICIENT = 4,329/7,612 = 0.57

NOTE: THERE IS NO OFFSITE DRAINAGE

SINCE THERE IS NO PUBLISHED RUNOFF COEFFICIENT FOR A WOODEN BOARDWALK OR ALUMINUM GANGWAY A VALUE OF 0.75 WAS ASSUMED

I CERTIFY UNDER PENALTY OF LAW THAT THIS PLAN WAS PREPARED AFTER A SITE VISIT TO THE LOCATIONS DESCRIBED HEREIN BY MYSELF OR MY AUTHORIZED AGENT UNDER MY SUPERVISION

David Freedman 5/16/2023
 DAVID FREEDMAN DATE
 P.E. - LICENSE NO. 14392, GSWCC LEVEL II CERTIFICATION NO. 66474